

# Product catalog

## Accessories and Consumables



Your first choice in digital cutting.

**ZÜND**  
swiss cutting systems

# Content

<b>1</b>	<b>Original Zünd accessories – the benefits.....</b>	<b>5</b>
1.1	Warranty limitation.....	5
<b>2</b>	<b>Blades .....</b>	<b>7</b>
2.1	General information.....	7
2.2	Overview of blades .....	17
2.3	Product description .....	26
2.4	Wild knives .....	91
<b>3</b>	<b>Routers .....</b>	<b>92</b>
3.1	RM-L / RM-A / RM-A QC / RM-A QC ARC / RM-S / R45-s .....	92
3.2	URT 300 W / PN 150/450 W.....	103
<b>4</b>	<b>Creasing wheels .....</b>	<b>108</b>
4.1	CTT2 - Creasing inserts.....	108
4.2	CTT1 - Crease wheel without support.....	109
4.3	CTT3 - Crease wheel without support.....	110
<b>5</b>	<b>Perforating knives .....</b>	<b>111</b>
5.1	Vinyls .....	111
5.2	Solid cardboard / Polypropylene.....	111
5.3	Corrugated cardboard .....	112
5.4	Knifeholder.....	113
<b>6</b>	<b>Punching bits.....</b>	<b>114</b>
6.1	HSS punching bits .....	114
6.2	Carbide punching bits.....	115
6.3	Notching bit.....	116
6.4	Punching pin .....	116
<b>7</b>	<b>Tools.....</b>	<b>117</b>
<b>8</b>	<b>Cutting accessories.....</b>	<b>118</b>
8.1	Blade holder, flat-stock drag blade.....	119
8.2	Blade holder, V-cut blade .....	120
8.3	Blade holder, PPT blade .....	122
8.4	EOT .....	123
8.5	EOT-250.....	124

## Imprint

Catalog version 02/2020  
Author Marketing & Communications, Zünd Systemtechnik AG  
Copyright Zünd Systemtechnik AG

8.6	Glide shoes.....	125
8.7	KCM-S, KCT, C2-, C2-P-modular tool heads.....	128
<b>9</b>	<b>Routing accessories .....</b>	<b>129</b>
9.1	Collets HSK-E 25, 3.6 kW milling spindle .....	129
9.2	Collets, 1 kW milling spindle .....	129
9.3	Collets, 1 kW milling spindle, QC .....	130
9.4	Collets, 300 W milling spindle .....	130
9.5	Collets, 150/450 W milling spindle.....	130
9.6	Consumables .....	131
<b>10</b>	<b>Plotting accessories .....</b>	<b>134</b>
10.1	Insert sleeves, cartridges/cartridge holders .....	134
10.2	Cartridges.....	135
<b>11</b>	<b>Cutting and routing underlays .....</b>	<b>136</b>
11.1	Bulk materials.....	138
11.2	Sealgrip routing underlay.....	138
11.3	Sealgrip W routing underlay .....	138
11.4	G3-Series .....	139
11.5	S3-Series.....	140
11.6	L3-Series.....	140
11.7	PN-Series.....	141
11.8	LC-Series .....	142
11.9	P-Series .....	142
<b>12</b>	<b>Conveyor belts .....</b>	<b>143</b>
12.1	Accessories.....	143
12.2	G3 series.....	143
12.3	S3 series .....	149
12.4	D3 series.....	151
12.5	PN series .....	153

## 1 Original Zünd accessories – the benefits

For us, perfection is about fulfilling our customers' wishes. Whatever the application, you will find the right tool in our Accessories Product Catalogue. Our customers' feedback on our 10,000+ installed systems is constantly being incorporated in the initial and further development of our accessories. This is how we ensure that our products constantly remain at the highest level. We always take note of requirements arising from the application of our systems by our customers, and these are constantly incorporated into the range in the form of new or improved products.

As a quality-conscious customer, you benefit from this commitment by being able to make optimum use of your Zünd cutter in terms of productivity and quality.

Rapid availability of high quality replacement parts is a decisive factor in daily operations. Only a manufacturer with a worldwide presence like Zünd can supply original accessories in such little time on a global scale. And if you don't have a catalogue to hand, you can also find all our accessories online at: [www.zund.com](http://www.zund.com).

### 1.1 Warranty limitation

The type of tool used for any given operation can greatly affect cut quality. Forces and vibrations that occur during processing reduce both the life-cycle of tools (EOT, POT, PRT, DRT, URT etc.) and the cut quality.

The combination of Zünd cutters, Zünd tools and Zünd original accessories is the result of many years' intensive development work. This includes continuous input from our customers and their applications. Zünd reserves the right to refuse warranty claims for defects in Zünd cutters caused by the use of non-original Zünd accessories.

## 2 Blades

### 2.1 General information

#### 2.1.1 Benefits at a glance

Zünd offers a broad range of quality blades, specially adapted to your cutting system and suitable for all your needs. This enables you to achieve a consistently high quality standard throughout the entire production process. Zünd blades are developed and manufactured specially by experts to meet market requirements.

#### Zünd blades offer crucial benefits:

- An excellent cutting result
- Low levels of waste/scrap
- Higher capacity utilization and shorter order times thanks to fewer blade changes
- We use only high performance materials
- Our quality remains constant

#### Original Zünd quality

Zünd blades are produced to the highest quality standards. All Zünd blades are recognizable through the Zünd quality seal with which they are engraved.



- 1 Zünd quality seal
- 2 Batch number
- 3 Blade name

### 2.1.2 Blade material

The material the blades are made from plays a major role with regard to the stability and the life expectancy of the blade. Zünd blades are made from carbide or high speed steel. Carbide blades have a significantly higher life expectancy than high speed steel blades, but high speed steel blades are much less susceptible to impacts and vibrations that can cause the tips to break.



#### Tip!

Never touch carbide blades or bring them into contact with hard objects.

#### The benefits of Zünd carbide blades:

- Longer life expectancy than high speed steel.
- Greater productivity thanks to fewer blade changes.
- Better cutting quality thanks to the blade's precision finish and very high stability.

Your Zünd service partners will be pleased to help you choose the best blade for your needs.

### 2.1.3 Blade shape and dimensions

Zünd blades are specifically designed and sharpened to handle a wide range of materials. The additional specifications provided for each blade contain a list of the materials for which it can be used.

#### Cutting angle

The cutting angle has a major influence on the cutting force. With drag blades, a narrow cutting angle means smaller drag forces.

However, this has the disadvantage of creating a larger overcut.

Drag blades



Oscillating blade – flat



Oscillating blade – pointed



### 2.1.4 Maximum cutting depth

There is a specified maximum cutting depth for each blade, which is determined by the length of the cutting edge. The cutting depth which can be achieved depends greatly on the Type of material. The cutting depth of some oscillating blades will be reduced when using the glide shoe. Please remember to factor in the set depth as well as the material thickness.

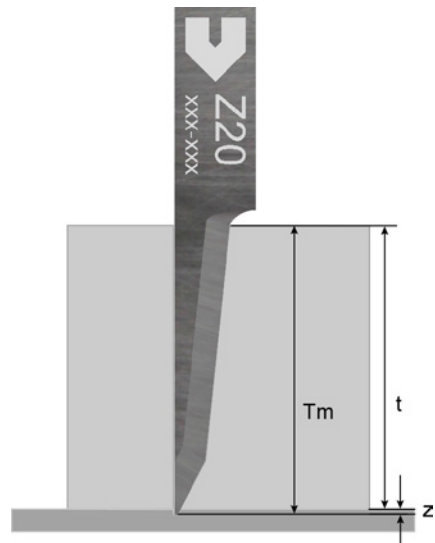

- t Material thickness
- z Set depth
- Tm Cutting depth = material thickness t + set depth z

### 2.1.5 Overcut x

The pre-cut:  $x_1$  is the distance from the centre of the axis of rotation to the first point where the cutting edge cuts the material surface in the direction of travel. The Post-cut:  $x_2$  is the measurement from the centre of the axis of rotation to the last point where the cutting edge cuts the material surface.

The cutting angle has the greatest influence on processing quality. A narrower cutting angle may enable faster cutting, but it also produces a greater overcut. A narrower cutting angle can be used for paths that include large curves and long straight sections.



#### Tip!

The overcut distorts the cutting contours. For cuts with a low margin of error, Zünd recommends choosing a blade with a smaller overcut. Overcut information can be found in the additional specifications for each blade.

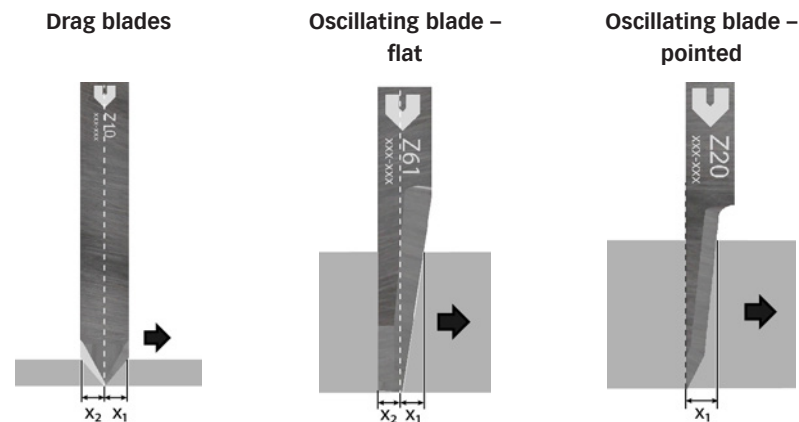

### 2.1.6 Calculating the overcut

Depending on the cutting depth, the blade geometry will produce a different level of overcut. This chapter explains how to calculate your overcut based on the blade you are using and the material you are cutting. The Z20 pointed oscillating blade and Z11 drag blade are used as examples here.

The cutting depth  $T_m$  is made up of the material thickness  $t$  and the set depth  $z$ . Insert these values into the formula as they are listed in the product description for each blade. The result will be the pre-cut:/post-cut: in mm.

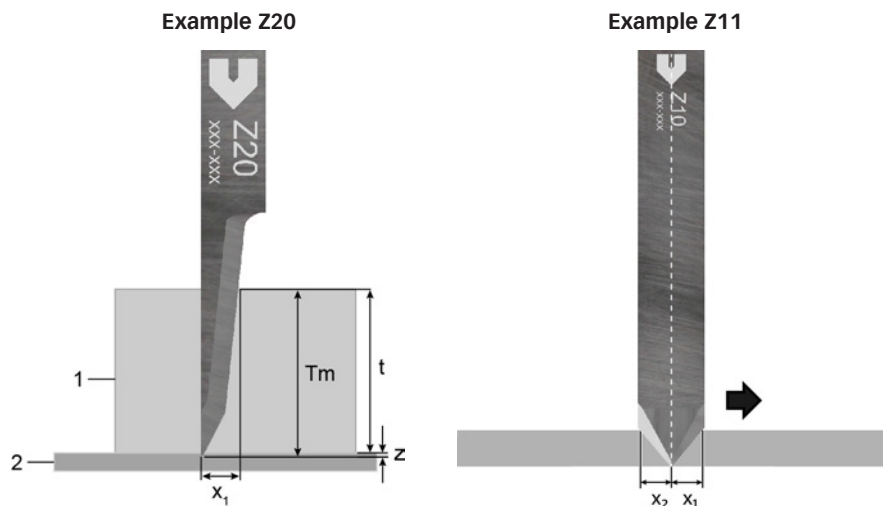

- 1 Material
- 2 Cutting underlay
- $t$  Material thickness
- $z$  Set depth
- $T_m$  Cutting depth = material thickness  $t$  + set depth  $z$
- $x_1$  Pre-cut
- $x_2$  Post-cut

#### Sample calculation Z20

<b>Formula</b>	$x = 1.2 + 0.11 \times T_m$
<b>Cutting depth</b>	$T_m = 10.2 \text{ mm}$
<b>Pre-cut:</b>	$x_1 = 2.322 \text{ mm}$

#### Sample calculation Z11

<b>Formula</b>	$x_{1,2} = 0.58 \times T_m$
<b>Cutting depth</b>	$T_m = 5,2 \text{ mm}$
<b>Pre-cut:</b>	$x_1 = 3.016 \text{ mm}$
<b>Post-cut:</b>	$x_2 = 3.016 \text{ mm}$

### 2.1.7 Blade Types

Depending on which tool they are used in, a distinction is made between the following blade Types:

- **Drag blades:** used in non-powered tools such as UCT, KCT, VCT, SCT, C2, insert sleeve 40)
- **Oscillating blades:** used in EOT/POT oscillating tools
- **Rotary blade:** decagonal (ten-sided) blades for DRT/PRT tools

#### Drag blades

Drag knives are used in combination with non-powered tools (UCT, KCT, VCT, SCT, C2).

**Round-stock blade**  
(e.g. Z1)



**Flat-stock blade**  
(e.g. Z10)



**Mat-cutting blade**  
(e.g. Z34)



**V-cut blade**  
(e.g. Z70)



- Maximum cutting speed; cheap to purchase and maintain
- High cutting force
- Particularly suitable for foils, paper, thin folding carton, banners, etc.
- Most cost-effective cutting option, as the purchase price for the associated tools (UCT, KCT, VCT, SCT, C2) is considerably lower than those for powered tools.

### Oscillating blades

The oscillating tool is mostly recommended for cutting thick and tough materials. The oscillating motion of the blade decreases the drag force exerted on the material in the direction of travel. However, to achieve this, the feed speed must be precisely adjusted to suit the selected oscillating blade and oscillation frequency. Choosing the right oscillating blade depends primarily on the contour to be cut:

- Zünd recommends flat blades for large radii, straight and large parts.
- Very sharp, pointed blades should only be used to cut small radii. The feed speed must be reduced to achieve a good quality cut.

**Flat blade (e.g. Z43)**



- High cutting speed
- Large radii, straight and/or large parts

**Pointed blade (e.g. Z20)**



- Low cutting speed
- Small radii and/or small parts



## Rotary blade

## Decagonal (ten-sided) blades



- Very high cutting speed
- Suitable for large radii, straight and/or large parts
- Recommended for breathable materials such as textile, carbon fibre, glass fibre, etc.
- Very large overcut

## 2.2 Overview of blades

## 2.2.1 Drag blades

## Round-stock blades (C2, C2P, KCT, KCM-S)

Figure	Item no.	Blade	Cutting depth [mm]	Pack. unit (pcs.)	Page
	3910105	Z1	1.0	1	26
	3910110	Z2	1.0	1	27
	3910115	Z3	1.0	1	28
	3910116	Z4	2.1	1	29
	3910154	W6	2.4	1	30
	3910117	Z5	2.6	1	31

## Flat-stock blades (UCT, SCT, insert sleeve 40)





















Figure	Item no.	Blade	Cutting depth [mm]	Pack. unit (pcs.)	Page
	3910303	Zünd Type 3	2.4/7.9	10	
	3910302	Zünd Type 2	2.7/4.9	10	
	3910301	Z10	4.8	1	32
	3910309	Z11	6.9	1	33
	5206878	Z83	4.6	1	34
	5217696	Z101	6.8	1	35
	3910310	Zünd Type 6	6.5	10	
	3910306	Z16	7.4	1	36
	5221104	Z104	11	1	<ÜS>
	3910307	Z17	12	1	38
	3910340	Z44	14.0	1	39

Figure	Item no.	Blade	Cutting depth [mm]	Pack. unit (pcs.)	Page
	5219266	Z103	14.0	1	<?>
	5219049	Z102	16.0	1	41
	4800073	Z46	20.0	1	42

## V-cut blades

Figure	Item no.	Blade	Cutting depth [mm]	Pack. unit (pcs.)	Page
	5005642	Z70	10.0/ 15.6	1	43
	5006045	Z71	16.0/ 18.4	1	44
	5005572	Z73	16.0/ 18.2	10	45

## Mat-cutting blades (PPT)

Figure	Item no.	Blade	Cutting depth [mm]	Pack. unit (pcs.)	Page
	3910330	Z30	2.0	1	46
	3910331	Z31	2.0	1	47
	3910333	Z33	5.0	1	48
	3910334	Z34	5.0	1	49
	4800071	Z35	5.0	1	50





## Oscillating blades

## Oscillating blade – pointed

Figure	Item no.	Blade	Cutting depth [mm]	Pack. unit (pcs.)	Page
	3910310	Zünd Type 6	6.5	10	
	3910306	Z16	7.4	1	51
	3910307	Z17	12	1	52
	3910315	Z22	14.0	1	53
	3910313	Z20	14.3	1	54
	5201345	Z60	16.5	1	55
	3910314	Z21	17.2	1	56
	5005560	Z23	22.0	1	57
	3910318	Z28	26.0	1	58
	3910319	Z29	31.0	1	59
	5200479	Z66	55.0	1	60

## Blades

Overview of blades











Figure	Item no.	Blade	Cutting depth [mm]	Pack. unit (pcs.)	Page
	5210315	Z608	56.0	1	61
	5210312	Z606	72.0	1	62
	5210310	Z604	92.0	1	63
	5210306	Z602	112.0	1	64

## Blades



Overview of blades

### Oscillating blade – flat

Figure	Item no.	Blade	Cutting depth [mm]	Pack. unit (pcs.)	Page
	3910324	Z42	7.8	1	65
	5203005	Z42-C	7.8	1	66
	3910325	Z43	7.8	1	67
	5221187	Z204	8.5	1	<?>
	3910317	Z26	8.7	1	69
	5205519	Z82	9.3	1	70
	5221104	Z104	11	1	<?>
	3910323	Z41	11.3	1	72
	5002488	Z62	13.2	1	73
	5209985	Z202	14.5	1	74
	5210145	Z203	17.0	1	75

Figure	Item no.	Blade	Cutting depth [mm]	Pack. unit (pcs.)	Page
	5209201	Z201	17.4	1	76
	5201343	Z61	20.0	1	77
	5002637	Z63	28.0	1	78
	5204301	Z68	29.0	1	79
	5204302	Z69	35.0	1	80
	5210317	Z607	56.0	1	81
	5002739	Z64	57.0	1	82
	5210319	Z605	72.0	1	83
	5210320	Z603	92.0	1	84
	5209223	Z601	112.0	1	85

## 1.1.1 Rotary blade

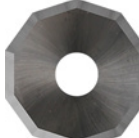
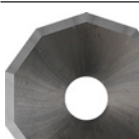
Figure	Item no.	Blade	Cutting depth [mm]	Pack. unit (pcs.)	Page
	4800059	Z53	2.0	1	86
	3910335	Z50	3.5	1	87
	3910336	Z51	5.0	1	88
	3910337	Z52	7.0	1	89

## 1.1.2 Wheel knives

Figure	Item no.	Blade	Cutting depth [mm]	Pack. unit (pcs.)	Page
	5205751	Z55	1	1	90

## 2.3 Product description

### Z1

Item no.: 3910105

#### Type

Round-stock drag blade

#### Properties

Blade for cutting any standard self-adhesive vinyls.

#### Recommended materials

- Self-adhesive vinyls
- Masking film
- Cardstock
- Pattern materials

#### Technical information

Pre-cut: 1.43 x Tm

Post-cut: -

Max. cutting depth: 1.0 mm

Blade material: Carbide

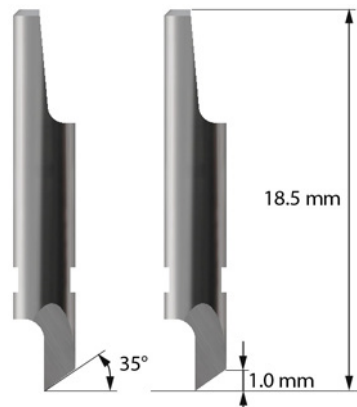

#### Intended use



KCT,  
Insert sleeve 40  
for vinyl blades



C2, C2P



KCM-S

### Z2

Item no.: 3910110

#### Type

Round-stock drag blade

#### Technical information

Pre-cut: 1.43 x Tm

Post-cut: -

Max. cutting depth: 1.0 mm

Blade material: Carbide

#### Properties

Blade for cutting any standard self-adhesive vinyls. Similar to the Z1, but exerts less drag force and has a shorter life expectancy.

#### Recommended materials

- Reflective vinyls
- Self-adhesive vinyls
- Masking film
- Cardstock
- Pattern materials

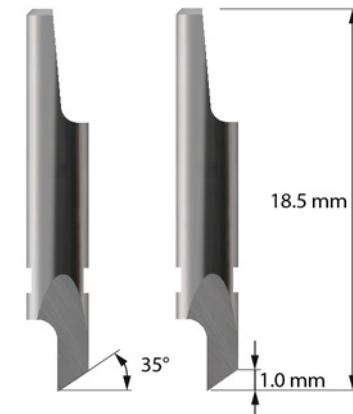

#### Intended use



KCT,  
Insert sleeve 40  
for vinyl blades



C2, C2P



KCM-S

**Z3****Item no.:** 3910115**Type**

Round-stock drag blade

**Technical information**

Pre-cut: 1.43 x Tm

Post-cut: 1.43 x Tm

Max. cutting depth: 1.0 mm

Blade material: Carbide

**Properties**

Fine blade for creating small lettering.  
Stable and long-life double-edged blade.

**Recommended materials**

- Self-adhesive vinyls
- Masking film

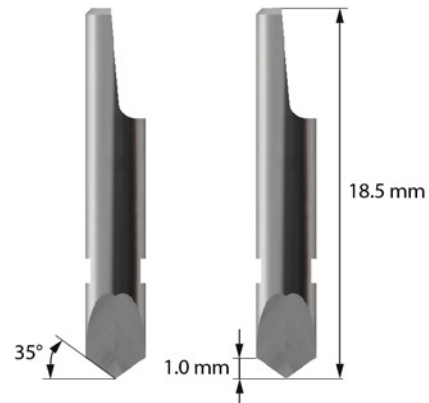
**Z4****Item no.:** 3910116**Type**

Round-stock drag blade

**Technical information**

Pre-cut: 0.7 x Tm

Post-cut: -

Max. cutting depth: 2.1 mm

Blade material: Carbide

**Properties**

Fine blade tip with small overcut;  
therefore somewhat less stable.

**Recommended materials**

- Sandblast vinyls
- Reflective vinyls
- Cardstock
- Pattern materials

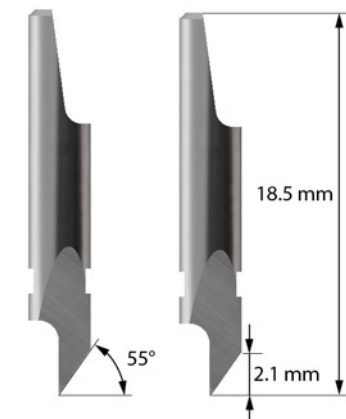
**Intended use**

KCT,  
Insert sleeve 40  
for vinyl blades



C2, C2P



KCM-S

**Intended use**

KCT,  
Insert sleeve 40  
for vinyl blades



C2, C2P



KCM-S

**W6****Item no.:** 3910154**Type**

Round-stock drag blade

**Technical information**

Pre-cut: 1.73 x Tm

Post-cut: -

Max. cutting depth: 2.4 mm

Blade material: Carbide

**Properties**

Robust all-round blade which exerts little drag force for large radii.

**Recommended materials**

- Paper
- Cardstock
- Tarpaulin material
- Plastic film

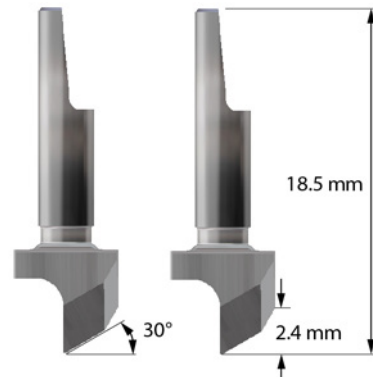
**Intended use**

KCT,  
Insert sleeve 40  
for vinyl blades



C2, C2P



KCM-S

**Z5****Item no.:** 3910117**Type**

Round-stock drag blade

**Technical information**

Pre-cut: 0.58 x Tm

Post-cut: -

Max. cutting depth: 2.6 mm

Blade material: Carbide

**Properties**

Very small overcut for vinyls and soft materials.

**Recommended materials**

- Sandblast vinyls
- Reflective vinyls
- Cardstock
- Pattern materials

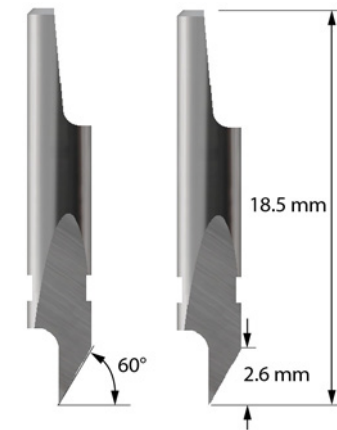
**Intended use**

KCT,  
Insert sleeve 40  
for vinyl blades



C2, C2P



KCM-S



**Z10****Item no.:** 3910301**Type**

Flat-stock drag blade

**Properties**

Stable and robust double-edged drag blade. Similar to Z11, but with a larger overcut and longer life expectancy.

**Recommended materials**

- Tarpaulin material
- PVC banners (frontlit/backlit)
- Polypropylene; PP
- Polyester fabric; coated textiles
- Polycarbonate; PC
- Folding carton; 100 - 1500 g
- Vinyl
- Hard foam core

**Technical information**

Pre-cut: 0.84 x Tm

Post-cut: 0.84 x Tm

Max. cutting depth: 4.8 mm

Blade thickness: 1.5 mm

Blade material: Carbide

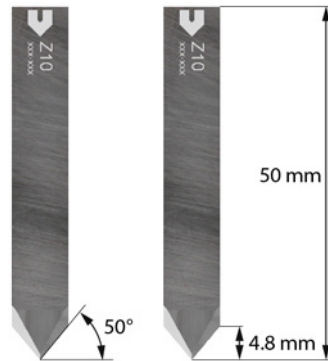
**Intended use**

UCT,  
Insert sleeve 40 +  
blade holder type 1  
(3960322)



SCT +  
blade holder type 1  
(3960322)

**Z11****Item no.:** 3910309**Type**

Flat-stock drag blade

**Properties**

Double-edged blade with universal applications. Similar to Z10, but with a smaller overcut and shorter life expectancy.

**Recommended materials**

- Tarpaulin material
- PVC banners (frontlit/backlit)
- Polypropylene; PP
- Polyester fabric; coated textiles
- Polycarbonate; PC
- Folding carton; 100 - 1500 g
- Vinyl
- Hard foam core

**Technical information**

Pre-cut: 0.58 x Tm

Post-cut: 0.58 x Tm

Max. cutting depth: 6.9 mm

Blade thickness: 1.5 mm

Blade material: Carbide

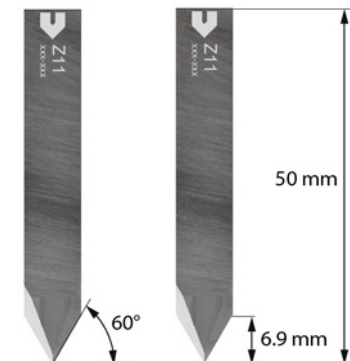
**Intended use**

UCT,  
Insert sleeve 40 +  
blade holder type 1  
(3960322)



SCT +  
blade holder type 1  
(3960322)

**Z83****Item no.:** 5206878**Type**

Flat-stock drag blade

**Properties**

Centric, asymmetrical drag blade for ridgefree inside cutting edge.

**Recommended materials**

- PVC
- Polycarbonate; PC
- Folding carton
- Hard foam core

**Technical information**

Pre-cut: 0.84 x Tm

Post-cut: 0.84 x Tm

Max. cutting depth: 4.6 mm

Blade thickness: 1.5 mm

Blade material: Carbide

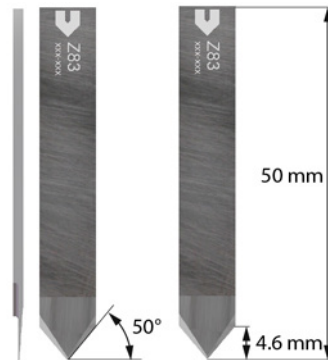
**Intended use**

UCT,  
Insert sleeve 40 +  
blade holder type 1  
(3960322)



SCT +  
blade holder type 1  
(3960322)

**Z101****Item no.:** 5217696**Type**

Flat-stock drag blade

**Properties**

Centric, asymmetrical drag blade for ridgefree inside cutting edge.

**Recommended materials**

- PVC
- Polycarbonate; PC
- Polypropylene; PP
- Folding Carton
- Hardfoam
- Magnetic foil

**Technical information**

Pre-cut: 0.58 x Tm

Post-cut: 0.58 x Tm

Max. cutting depth: 6.8 mm

Blade thickness: 1.5 mm

Blade material: Carbide

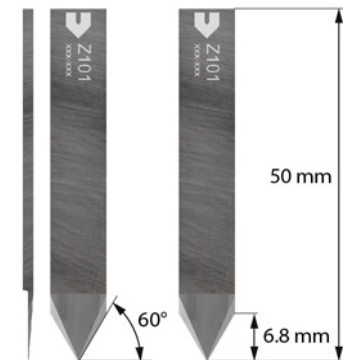
**Intended use**

UCT,  
Insert sleeve 40 +  
blade holder type 1  
(3960322)



SCT +  
blade holder type 1  
(3960322)

**Z16****Item no.:** 3910306**Type**Flat-stock drag blade/  
Oscillating blade – pointed**Properties**Blade for soft materials. Universally  
applicable as a robust oscillating blade.**Recommended materials**

- Magnetic material
- Polycarbonate; PC
- Polyester film
- Coating blanket
- Paper; 100 - 400 g
- Folding carton; 100 - 1500 g

**Technical information**

Pre-cut: 0.75 x Tm

Post-cut: -

Max. cutting depth: 7.4 mm

Blade thickness: 0.63 mm

Blade material: Carbide

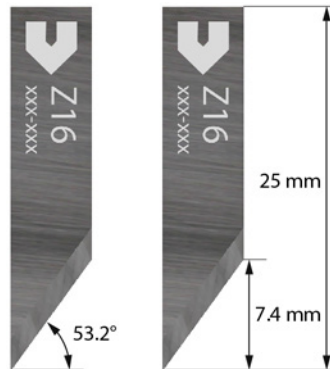
**Intended use**UCT,  
Insert sleeve 40 +  
blade holder  
type 3  
(3960324)SCT +  
blade holder  
type 3  
(3960324)PCT +  
blade holder  
type 3  
(3960324)**Z104****Item no.:** 5221104**Type**Flat-stock drag blade/  
Oscillating blade – flat**Properties**Blade designed for cutting thin materials,  
suitable for small radii.**Recommended materials**

- Corrugated cardboard (7 mm)

**Technical information**

Pre-cut: 1.4 + 0.18 x Tm

Post-cut: -

Max. cutting depth: 11 mm

Blade thickness: 0.63 mm

Blade material: Carbide

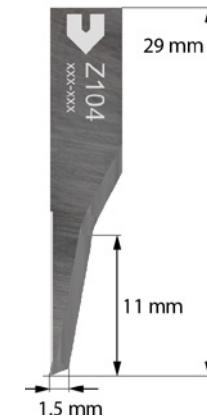
**Verwendung**PCT +  
blade holder  
type 3  
(3960324)

**Z17**

Item no.: 3910307

**Type**

Flat-stock drag blade/  
Oscillating blade – pointed

**Properties**

Blade for cutting thin materials. The overcut is smaller, but the blade exerts more drag force on the material than the Z16. For best results, use as an oscillating blade.

**Recommended materials**

- Magnetic material
- Polycarbonate; PC
- Polyester film
- Coating blanket
- Paper; 100 - 400 g
- Folding carton; 100 - 1500 g

**Technical information**

Pre-cut: 0.47 x Tm

Post-cut: -

Max. cutting depth: 12 mm

Blade thickness: 0.63 mm

Blade material: Carbide

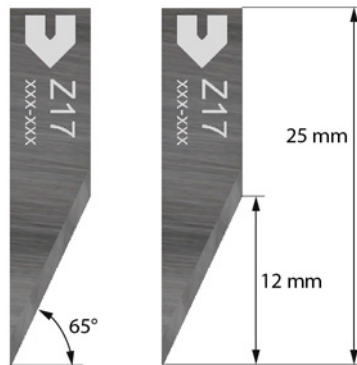
**Intended use**

UCT,  
Insert sleeve 40 +  
blade holder  
type 3  
(3960324)

SCT +  
blade holder  
type 3  
(3960324)

PCT +  
blade holder  
type 3  
(3960324)

**Z44**

Item no.: 3910340

**Type**

Flat-stock drag blade

**Properties**

Double-sided blade for less tough, fibrous materials. This blade offers similar properties to Z11.

**Recommended materials**

- Carpet
- Tarpaulin material

**Technical information**

Pre-cut: 0.58 x Tm

Post-cut: 0.58 x Tm

Max. cutting depth: 14 mm

Blade thickness: 1.5 mm

Blade material: Carbide

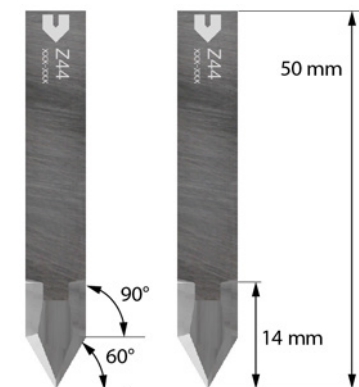
**Intended use**

UCT,  
Insert sleeve 40 +  
blade holder type 1  
(3960322)

SCT +  
blade holder type 1  
(3960322)

**Z103****Item no.:** 5219266**Type**

Flat-stock drag blade

**Properties**

Double-sided blade for less tough, fibrous materials. This blade offers similar properties to Z11.

**Recommended materials**

- Carpet
- Tarpaulin material

**Technical information**

Pre-cut: 0.7 x Tm

Post-cut: 0.7 x Tm

Max. cutting depth: 14 mm

Blade thickness: 1.5 mm

Blade material: Carbide

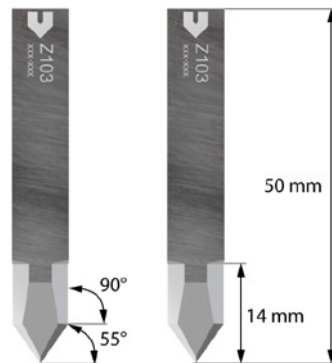
**Intended use**

UCT,  
Insert sleeve 40 +  
blade holder type 1  
(3960322)



SCT +  
blade holder type 1  
(3960322)

**Z102****Item no.:** 5219049**Type**

Flat-stock drag blade

**Properties**

Blade for light, soft materials. Exerts little drag force, but has a larger overcut.

**Recommended materials**

- Corrugated plastic
- Light foam core
- PVC banners
- Paper
- Polyester fabric
- Tarpaulin material

**Technical information**

Pre-cut: 1.0 x Tm

Post-cut: -

Max. cutting depth: 7.8 mm

Blade thickness: 1.5 mm

Blade material: Carbide

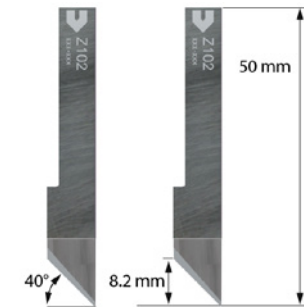
**Intended use**

UCT,  
Insert sleeve 40 +  
blade holder type 5  
(3960320)



SCT +  
blade holder type 5  
(3960320)

**Z46****Item no.:** 4800073**Type**

Flat-stock drag blade

**Properties**

Blade for light, soft materials. Exerts little drag force, but has a larger overcut.

**Recommended materials**

- Carpet
- Corrugated plastic
- Light foam core
- PVC banners (frontlit/backlit)

**Technical information**

Pre-cut: 1.0 x Tm

Post-cut: -

Max. cutting depth: 20 mm

Blade thickness: 1.5 mm

Blade material: Carbide

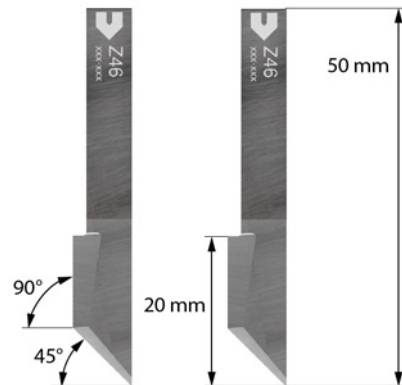
**Intended use**

UCT,  
Insert sleeve 40 +  
blade holder type 5  
(3960320)



SCT +  
blade holder type 5  
(3960320)

**Z70****Item no.:** 5005642**Type**

V-cut drag blade

**Properties**

Blade for a 45° cut.

**Recommended materials**

- Corrugated cardboard, sandwich board
- Light foam core
- Corrugated cardboard – BCA flute
- Carpet
- Corrugated plastic

**Technical information**

Max. cutting depth:

3102186: 15.6 mm

5005782: 11.9 mm

Blade thickness: 0.63 mm

Blade material: Carbide

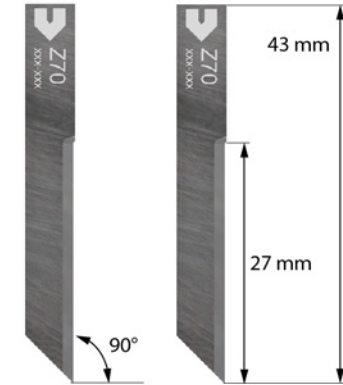
**Intended use**

T75 +  
Use for V-cut (3102186),  
blade holder (5005782)

**Z71****Item no.:** 5006045**Type**

V-cut drag blade

**Properties**

Stable, long-life carbide blade.

**Recommended materials**

- Corrugated cardboard, sandwich board
- Light foam core
- Corrugated cardboard – BCA flute
- Carpet
- Corrugated plastic

**Technical information**

Max. cutting depth:

5206263: 11.8 mm

5206264: 18.4 mm

Blade thickness: 1 mm

Blade material: Carbide

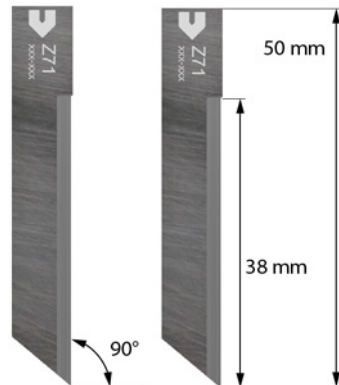
**Intended use**

VCT +  
blade holder; up to  
10 mm cutting depth  
(5206263)



VCT +  
blade holder; up to  
16 mm cutting depth  
(5206264)

**Z73****Item no.:** 5005572**Type**

V-cut drag blade

**Properties**

Stable high speed steel blade

**Recommended materials**

- Corrugated cardboard, sandwich board
- Light foam core
- Corrugated cardboard – BCA flute
- Carpet
- Corrugated plastic

**Technical information**

Max. cutting depth:

blade holder: 18.2 mm

Use for V-cut: 18.2 mm

Blade thickness: 0.9 mm

Blade material: HSS

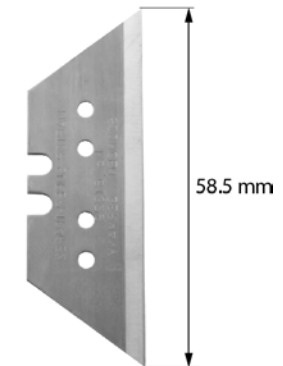
**Intended use**

VCT +  
blade holder; up to  
16 mm cutting depth  
(5206262)



T75 +  
Use for V-cut  
(3102186)

**Z30****Item no.:** 3910330**Type**

Mat-cutting blade

**Technical information**

Max. cutting depth: 2 mm

Blade thickness: 0.63 mm

Blade material: Carbide

**Properties**

Small mat-cutting blade for cutting straight lines and sharp corners from the back of the matboard.

**Recommended materials**

- Matboard

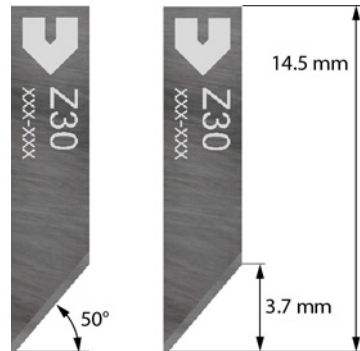
**Intended use**

PPT +  
blade holder; up to  
2 mm cutting depth  
(3960331)

**Z31****Item no.:** 3910331**Type**

Mat-cutting blade

**Technical information**

Max. cutting depth: 2 mm

Blade thickness: 0.63 mm

Blade material: Carbide

**Properties**

Small mat-cutting blade; multifunctional with two cutting edges to cut straight lines from the back of the matboard and radii from the front of the matboard.

**Recommended materials**

- Matboard

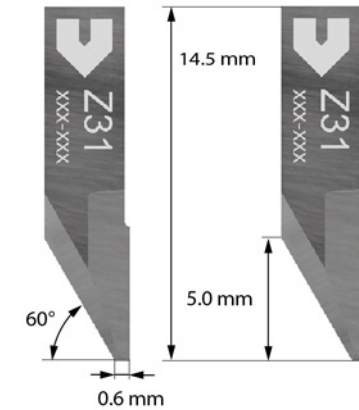
**Intended use**

PPT +  
blade holder; up to  
2 mm cutting depth  
(3960331)



**Z33****Item no.:** 3910333**Type**

Mat-cutting blade

**Technical information**

Max. cutting depth: 5 mm

Blade thickness: 0.63 mm

Blade material: Carbide

**Properties**

Large mat-cutting blade for cutting straight lines and sharp corners on the back of the matboard.

**Recommended materials**

- Matboard

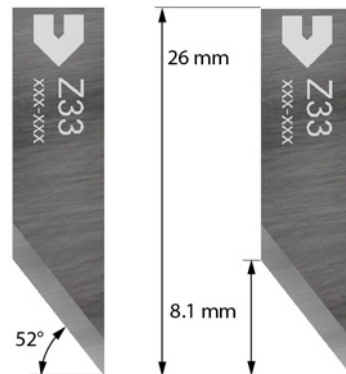
**Intended use**

PPT +  
blade holder; up to  
5 mm cutting depth  
(3960328)

**Z34****Item no.:** 3910334**Type**

Mat-cutting blade

**Technical information**

Max. cutting depth: 5 mm

Blade thickness: 0.63 mm

Blade material: Carbide

**Properties**

Large mat-cutting blade; multifunctional with two cutting edges to cut straight lines from the back of the matboard and radii from the front of the matboard.

**Recommended materials**

- Matboard

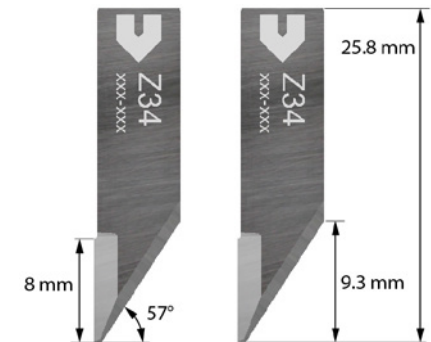
**Intended use**

PPT +  
blade holder; up to  
5 mm cutting depth  
(3960328)



PPT +  
blade holder; up  
to 2.5 mm cutting  
depth (3960329)

**Z35**

Item no.: 4800071

**Type**

Mat-cutting blade

**Technical information**

Max. cutting depth: 5 mm  
 Blade thickness: 0.63 mm  
 Blade material: Carbide

**Properties**

Large mat-cutting blade for cutting straight lines and sharp corners from the front of the matboard.

**Recommended materials**

- Matboard

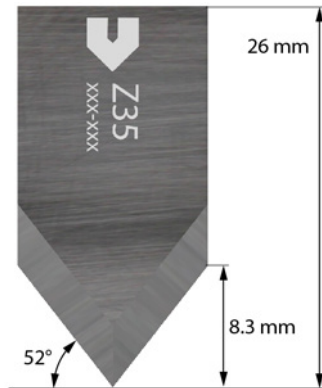

**Intended use**



PPT + blade holder; up to 5 mm cutting depth (3960330)

**Z16**

Item no.: 3910306

**Type**

Flat-stock drag blade/  
 Oscillating blade – pointed

**Technical information**

Pre-cut: 0.73 x Tm  
 Post-cut: -  
 Max. cutting depth: 7.4 mm  
 Blade thickness: 0.63 mm  
 Blade material: Carbide

**Properties**

For soft materials. Universally applicable as a robust oscillating blade.

**Recommended materials**

- Folding carton; 100 - 1500 g
- Gasket materials
- Foam
- Leather

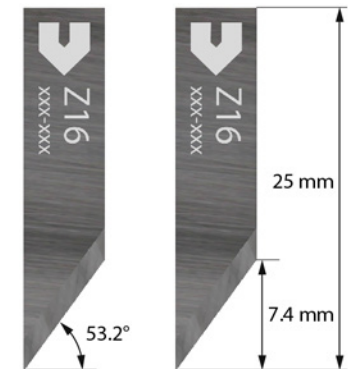

**Intended use**



EOT



EOT-250 + blade holder (5208744)



POT, blade holder 0.63 mm



POT, blade holder 1.5 mm + blade reduction 1.5/0.63 mm (5003138)

**Z17**

**Item no.:** 3910307

**Type**

Flat-stock drag blade/  
Oscillating blade – pointed

**Properties**

Blade for cutting thin materials. The overcut is smaller, but the blade exerts more drag force than the Z16. For best results, use as an oscillating blade.

**Recommended materials**

- Folding carton; 100 - 1500 g
- Gasket materials
- Foam
- Leather

**Technical information**

Pre-cut: 0.47 x Tm  
Post-cut: -  
Max. cutting depth: 12 mm  
Blade thickness: 0.63 mm  
Blade material: Carbide

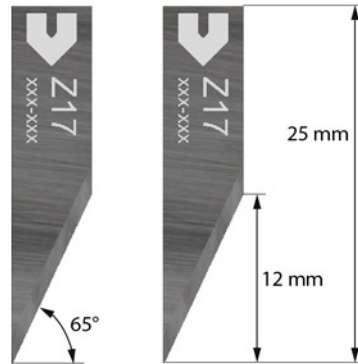

**Intended use**



EOT



EOT-250 +  
blade holder  
(5208744)



POT,  
blade holder  
0.63 mm



POT, blade holder  
1.5 mm +  
blade reduction 1.5/  
0.63 mm (5003138)

**Z22**

**Item no.:** 3910315

**Type**

Oscillating blade – pointed

**Properties**

Fine, robust blade with low overcut; designed to cut small radii and intricate detail. Similar to Z20, but more robust and with a larger overcut.

**Recommended materials**

- Corrugated cardboard; B, C, BC, EB and E flute
- Light foam core
- Foam
- Folding carton; 100 - 1500 g
- Polyester fabric; coated textiles
- Rubber, ejection rubber
- Magnetic material
- Corrugated plastic
- Felt

**Technical information**

Pre-cut: 1.2 + 0.2 x Tm  
Post-cut: -  
Max. cutting depth: 14 mm  
Blade thickness: 0.63 mm  
Blade material: Carbide

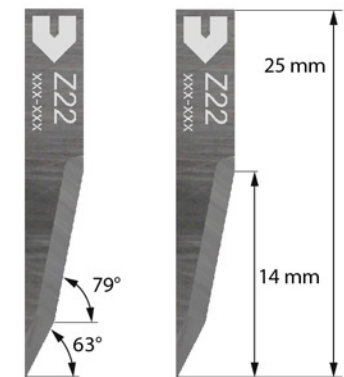

**Intended use**



EOT



EOT-250 +  
blade holder  
(5208744)



POT,  
blade holder  
0.63 mm



POT, blade holder  
1.5 mm +  
blade reduction 1.5/  
0.63 mm (5003138)

**Z20****Item no.:** 3910313**Type**

Oscillating blade – pointed

**Properties**

Very fine, delicate blade with minimal overcut; designed to cut small radii and intricate detail.

**Recommended materials**

- Corrugated cardboard; B, C, BC, EB and E flute
- Folding carton; 100 - 1500 g
- Light foam core
- Foam
- Ejection rubber
- Felt

**Technical information**

Pre-cut: 1.2 + 0.11 x Tm

Post-cut: -

Max. cutting depth: 14.3 mm

Blade thickness: 0.63 mm

Blade material: Carbide

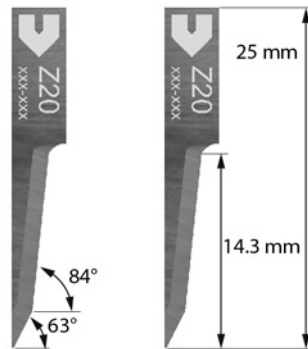
**Intended use**

EOT

EOT-250 +  
blade holder  
(5208744)POT,  
blade holder  
0.63 mmPOT, blade holder  
1.5 mm +  
blade reduction 1.5/  
0.63 mm (5003138)**Z60****Item no.:** 5201345**Type**

Oscillating blade – pointed

**Properties**

Strong blade for tough materials; similar to Z21.

**Recommended materials**

- Saddle leather, leather
- Rubber
- Corrugated plastic

**Technical information**

Pre-cut: 2.2 + 0.15 x Tm

Post-cut: -

Max. cutting depth: 16.5 mm

Blade thickness: 1.5 mm

Blade material: Carbide

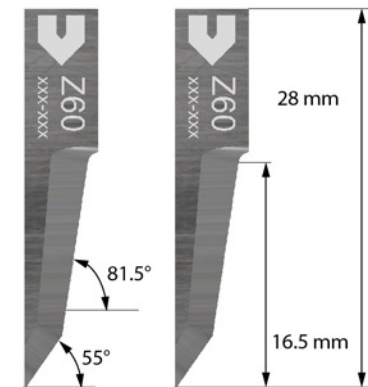
**Intended use**

EOT-250

POT,  
blade holder  
1.5 mm

**Z21**

Item no.: 3910314

**Type**

Oscillating blade – pointed

**Properties**

Fine blade with low overcut; designed to cut small radii and intricate detail.

**Recommended materials**

- Corrugated cardboard
- Light foam core
- Foam
- Rubber, ejection rubber
- Felt

**Technical information**

Pre-cut: 1.6 + 0.11 x Tm

Post-cut: -

Max. cutting depth: 17.2 mm

Blade thickness: 0.63 mm

Blade material: Carbide

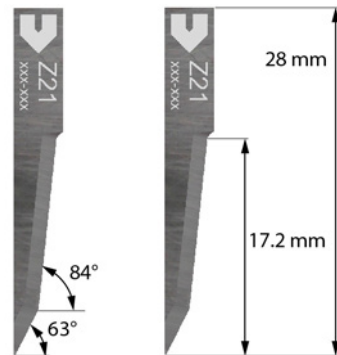
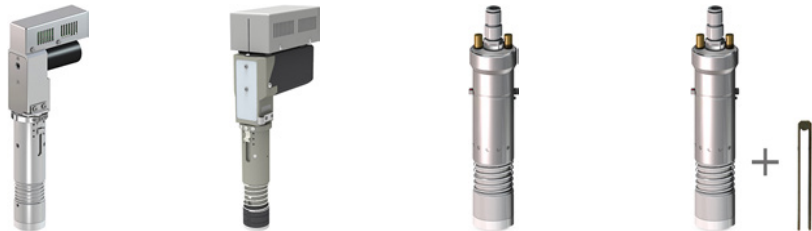
**Intended use**

EOT

EOT-250 +  
blade holder  
(5208744)POT,  
blade holder  
0.63 mmPOT, blade holder  
1.5 mm +  
blade reduction 1.5/  
0.63 mm (5003138)**Z23**

Item no.: 5005560

**Type**

Oscillating blade – pointed

**Properties**

Fine, long blade; designed to cut small radii and intricate detail.

**Recommended materials**

- Foam
- Insulating mat
- Sandwich board

**Technical information**

Pre-cut: 1.8 + 0.1 x Tm

Post-cut: -

Max. cutting depth: 22 mm

Blade thickness: 0.63 mm

Blade material: Carbide

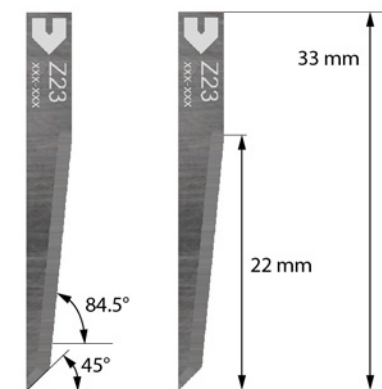
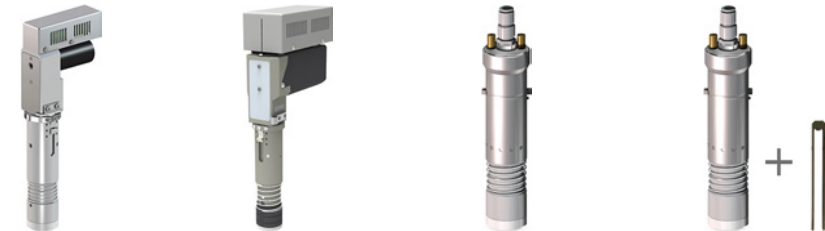
**Intended use**

EOT

EOT-250 +  
blade holder  
(5208744)POT,  
blade holder  
0.63 mmPOT, blade holder  
1.5 mm +  
blade reduction 1.5/  
0.63 mm (5003138)

**Z28**

Item no.: 3910318

**Type**

Oscillating blade – pointed

**Technical information**

Pre-cut: 1.9 + 0.07 x Tm

Post-cut: -

Max. cutting depth: 26 mm

Blade thickness: 0.63 mm

Blade material: Carbide

**Properties**

Long oscillating blade for soft, thick materials.

**Recommended materials**

- Foam
- Insulating mat

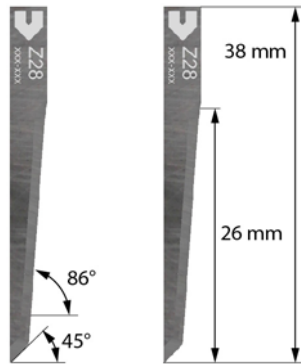

**Intended use**



EOT

EOT-250 +  
blade holder  
(5208744)

POT,  
blade holder  
0.63 mm

POT, blade holder  
1.5 mm +  
blade reduction 1.5/  
0.63 mm (5003138)

**Z29**

Item no.: 3910319

**Type**

Oscillating blade – pointed

**Technical information**

Pre-cut: 1.9 + 0.06 x Tm

Post-cut: -

Max. cutting depth: 31 mm

Blade thickness: 0.63 mm

Blade material: Carbide

**Properties**

Long oscillating blade for soft, thick materials. Similar to Z28, but longer.

**Recommended materials**

- Foam
- Insulating mat

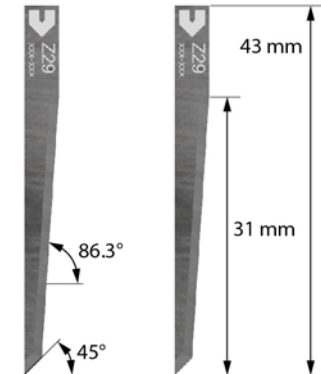

**Intended use**

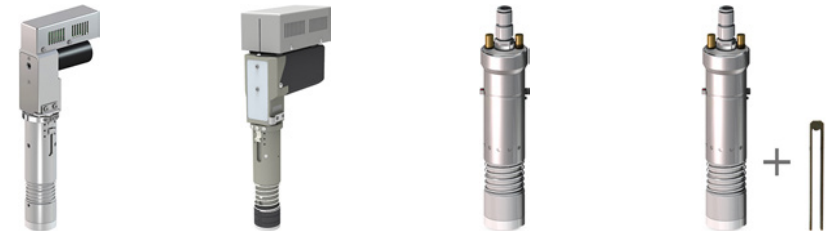

EOT

EOT-250 +  
blade holder  
(5208744)

POT,  
blade holder  
0.63 mm

POT, blade holder  
1.5 mm +  
blade reduction 1.5/  
0.63 mm (5003138)

**Z66**

Item no.: 5200479

**Type**

Oscillating blade – pointed

**Properties**

Long blade with serrated cutting edge.

**Recommended materials**

- Foam
- Insulating mat
- Corrugated cardboard – special flute design

**Technical information**Pre-cut:  $3.9 + 0.04 \times Tm$ 

Post-cut: -

Max. cutting depth: 55 mm

Blade thickness: 1.5 mm

Blade material: Carbide

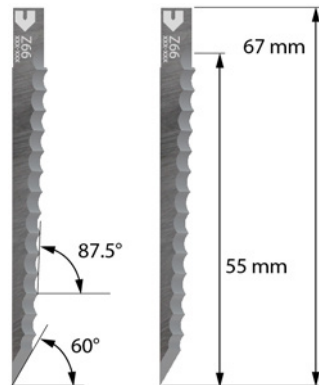
**Intended use**

POT,  
blade holder  
1.5 mm

**Z608**

Item no.: 5210315

**Type**

Oscillating blade – pointed

**Properties**Oscillating blade for soft foam up to 54 mm thickness and  $< 45 \text{ kg/m}^3$ **Recommended materials**

- Foam

**Technical information**Pre-cut:  $3.8 + 0.03 \times Tm$ 

Post-cut: -

Max. cutting depth: 56 mm

Blade thickness: 1.5 mm

Blade material: HSS

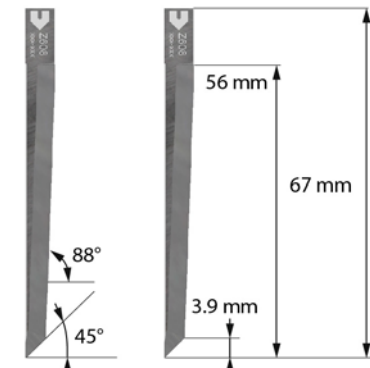
**Intended use**

EOT-250



POT,  
blade holder  
1.5 mm

**Z606****Item no.:** 5210312**Type**

Oscillating blade – pointed

**Properties**Oscillating blade for soft foam up to 70 mm thickness and < 45 kg/m<sup>3</sup>**Recommended materials**

- Foam

**Technical information**

Pre-cut: 3.8 + 0.03 x Tm

Post-cut: -

Max. cutting depth: 72 mm

Blade thickness: 1.5 mm

Blade material: HSS

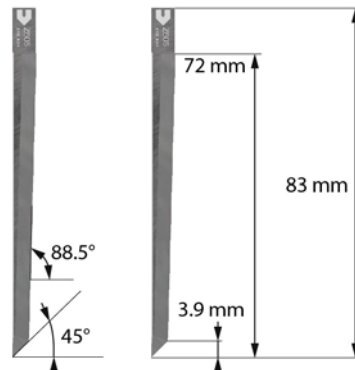
**Intended use**

EOT-250

POT,  
blade holder  
1.5 mm**Z604****Item no.:** 5210310**Type**

Oscillating blade – pointed

**Properties**Oscillating blade for soft foam up to 90 mm thickness and < 45 kg/m<sup>3</sup>**Recommended materials**

- Foam

**Technical information**

Pre-cut: 3.8 + 0.02 x Tm

Post-cut: -

Max. cutting depth: 92 mm

Blade thickness: 1.5 mm

Blade material: HSS

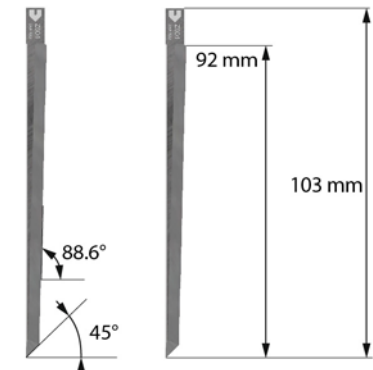
**Intended use**

EOT-250

POT,  
blade holder  
1.5 mm



**Z602**

Item no.: 5210306

**Type**

Oscillating blade – pointed

**Properties**

Oscillating blade for soft foam up to 110 mm thickness and <math> < 45 \text{ kg/m}^3 </math>

**Recommended materials**

- Foam

**Technical information**Pre-cut:  $3.8 + 0.02 \times T_m$ 

Post-cut: -

Max. cutting depth: 112 mm

Blade thickness: 1.5 mm

Blade material: HSS

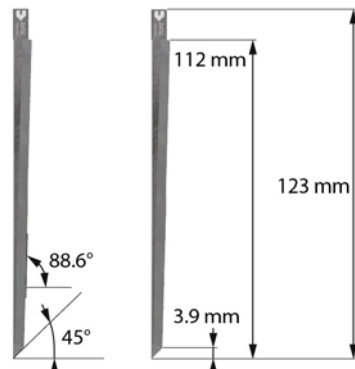
**Intended use**

EOT-250



POT,  
blade holder  
1.5 mm

**Z42**

Item no.: 3910324

**Type**

Oscillating blade – flat

**Properties**

Robust oscillating blade with small pre-cut.  
Similar to Z26.

**Recommended materials**

- Leather
- Woven materials, textiles
- Corrugated cardboard

**Technical information**Pre-cut:  $0.7 \times T_m$ 

Post-cut: 0.80 mm

Max. cutting depth: 7.8 mm

Blade thickness: 0.63 mm

Blade material: Carbide

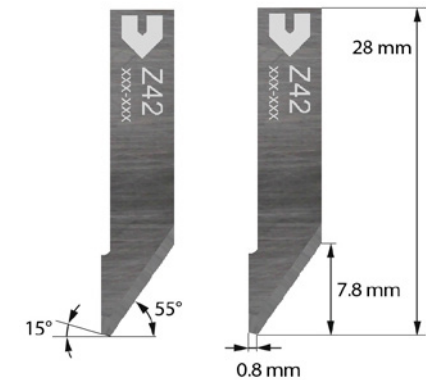
**Intended use**

EOT



EOT-250 +  
blade holder  
(5208744)



POT,  
blade holder  
0.63 mm

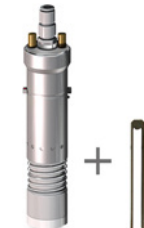

POT, blade holder  
1.5 mm +  
blade reduction 1.5/  
0.63 mm (5003138)

**Z42c (coated)**

Item no.: 5203005

**Type**

Oscillating blade – flat

**Properties**

Robust oscillating blade with the same geometry as Z42. The blade is specially coated to increase life expectancy for leather cutting.

**Recommended materials**

- Leather

**Technical information**

Pre-cut: 0.7 x Tm  
 Post-cut: 0.80 mm  
 Max. cutting depth: 7.8 mm  
 Blade thickness: 0.63 mm  
 Blade material: Carbide

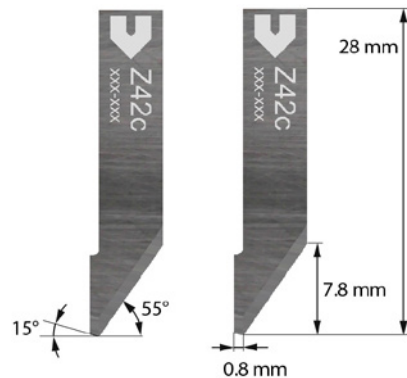

**Intended use**



EOT  
 EOT-250 + blade holder (5208744)  
 POT, blade holder 0.63 mm  
 POT, blade holder 1.5 mm + blade reduction 1.5/0.63 mm (5003138)

**Z43**

Item no.: 3910325

**Type**

Oscillating blade – flat

**Properties**

Robust oscillating blade. Similar to Z42, but with smaller pre-cut and larger postcut.

**Recommended materials**

- Leather
- Woven materials, textiles
- Corrugated cardboard

**Technical information**

Pre-cut: -0.8 + 0.7 x Tm  
 Post-cut: 1.55 mm  
 Max. cutting depth: 7.8 mm  
 Blade thickness: 0.63 mm  
 Blade material: Carbide

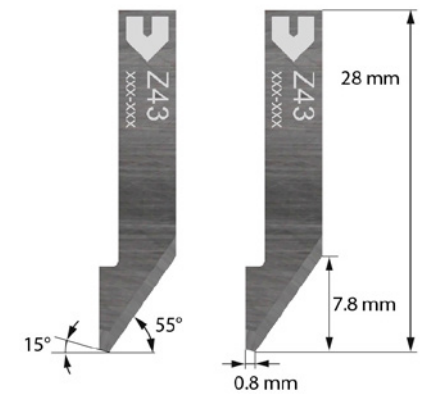

**Intended use**



EOT  
 EOT-250 + blade holder (5208744)  
 POT, blade holder 0.63 mm  
 POT, blade holder 1.5 mm + blade reduction 1.5/0.63 mm (5003138)

**Z204**

Item no.: 5221187

**Type**

Oscillating blade – flat

**Properties**

Thin, sharp-pointed blade with minimal overcut for cutting fine details, small radii.

**Recommended materials**

- Leather

**Technical information**

Pre-cut: 0.67 + 0.12 x Tm

Post-cut: -

Max. cutting depth: 8.5 mm

Blade thickness: 0.63 mm

Blade material: Carbide

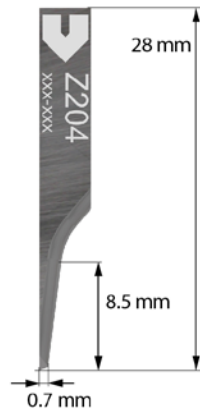
**Intended use**

EOT

EOT-250 +  
blade holder  
(5208744)POT,  
blade holder  
0.63 mmPOT, blade holder  
1.5 mm +  
blade reduction 1.5/  
0.63 mm (5003138)**Z26**

Item no.: 3910317

**Type**

Oscillating blade – flat

**Properties**

Simple, robust oscillating blade.

**Recommended materials**

- Woven materials, textiles
- Leather
- Corrugated cardboard
- Felt
- Rubber
- Sandwich board

**Technical information**

Pre-cut: 1.2 + 0.51 x Tm

Post-cut: -

Max. cutting depth: 8.7 mm

Blade thickness: 0.63 mm

Blade material: Carbide

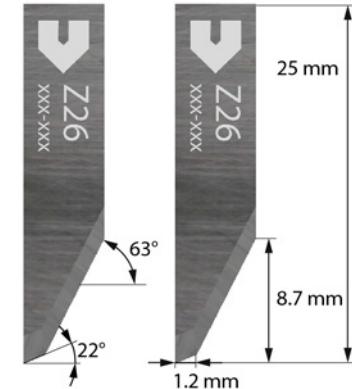
**Intended use**

EOT

EOT-250 +  
blade holder  
(5208744)POT,  
blade holder  
0.63 mmPOT, blade holder  
1.5 mm +  
blade reduction 1.5/  
0.63 mm (5003138)

**Z82**

Item no.: 5205519

**Type**

Oscillating blade – flat

**Properties**

Only use with strong cutting underlay (PLP).

**Recommended materials**

- Reinforced graphite gasket

**Technical information**

Pre-cut: 2.2 + 0.36 x Tm

Post-cut: -

Max. cutting depth: 9.3 mm

Blade thickness: 1.5 mm

Blade material: Carbide

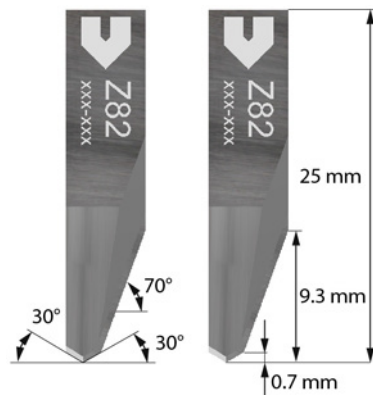
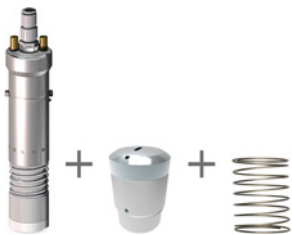
**Intended use**

POT, blade holder 1.5 mm +  
gliding disc (5205984) +  
spring insert low (3120030)

**Z104**

Item no.: 5221104

**Type**Flat-stock drag blade/  
Oscillating blade – flat**Properties**Blade designed for cutting thin materials,  
suitable for small radii.**Recommended materials**

- Corrugated cardboard (7 mm)

**Technical information**

Pre-cut: 1.4 + 0.18 x Tm

Post-cut: -

Max. cutting depth: 11 mm

Blade thickness: 0.63 mm

Blade material: Carbide

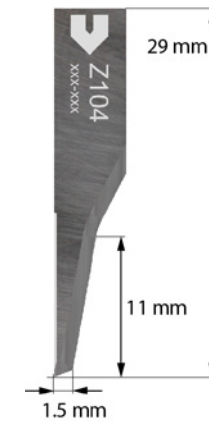
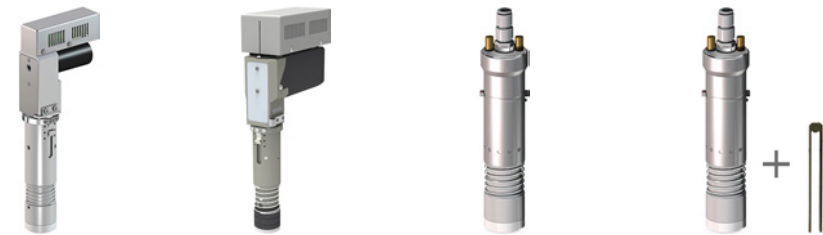
**Intended use**

EOT

EOT-250 +  
blade holder  
(5208744)

POT,  
blade holder  
0.63 mm

POT, blade holder  
1.5 mm +  
blade reduction 1.5/  
0.63 mm (5003138)

**Z41**

Item no.: 3910323

**Type**

Oscillating blade – flat

**Technical information**

Pre-cut: 0.8 + 0.18 x Tm

Post-cut: 1.20 mm

Max. cutting depth: 11.3 mm

Blade thickness: 0.63 mm

Blade material: Carbide

**Properties**

Oscillating blade with small pre-cut.

**Recommended materials**

- Leather
- Corrugated cardboard
- Woven materials, textiles
- Felt
- Foam

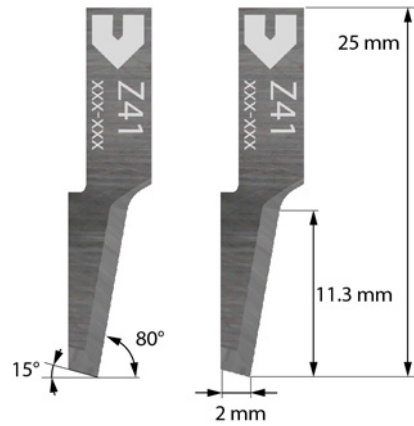

**Intended use**



EOT



EOT-250 +  
blade holder  
(5208744)



POT,  
blade holder  
0.63 mm



POT, blade holder  
1.5 mm +  
blade reduction 1.5/  
0.63 mm (5003138)

**Z62**

Item no.: 5002488

**Type**

Oscillating blade – flat

**Technical information**

Pre-cut: 0.8 + 0.21 x Tm

Post-cut: 1.20 mm

Max. cutting depth: 13.2 mm

Blade thickness: 0.63 mm

Blade material: Carbide

**Properties**

Oscillating blade with small pre-cut. Similar to Z41, but longer.

**Recommended materials**

- Leather
- Corrugated cardboard
- Woven materials, textiles
- Felt
- Foam

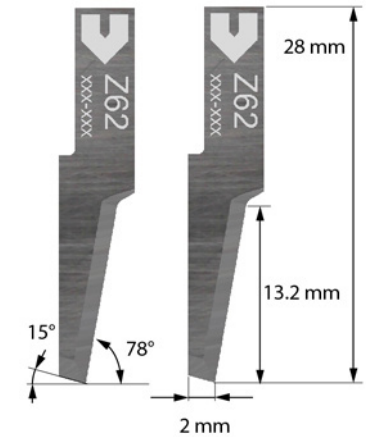

**Intended use**



EOT



EOT-250 +  
blade holder  
(5208744)



POT,  
blade holder  
0.63 mm



POT, blade holder  
1.5 mm +  
blade reduction 1.5/  
0.63 mm (5003138)

**Z202****Item no.:** 5209985**Type**

Oscillating blade – flat

**Properties**

Oscillating blade with multifaceted bidirectional cutting edge for high-speed cutting of 10 mm paper-based honeycomb/corrugated display board.

**Recommended materials**

- Corrugated sandwich 10 mm

**Technical information**

Pre-cut: 5.5 mm

Post-cut: -

Max. cutting depth: 14.5 mm

Blade thickness: 1.5 mm

Blade material: Carbide

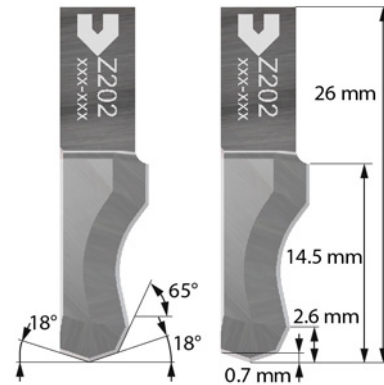
**Intended use**

EOT-250

**Z203****Item no.:** 5210145**Type**

Oscillating blade – flat

**Properties**

Oscillating blade with multifaceted bidirectional cutting edge for high-speed cutting of 12.7 mm paper-based honeycomb/corrugated display board.

**Recommended materials**

- Corrugated sandwich 12.7 mm

**Technical information**

Pre-cut: 5.5 mm

Post-cut: -

Max. cutting depth: 17 mm

Blade thickness: 1.5 mm

Blade material: Carbide

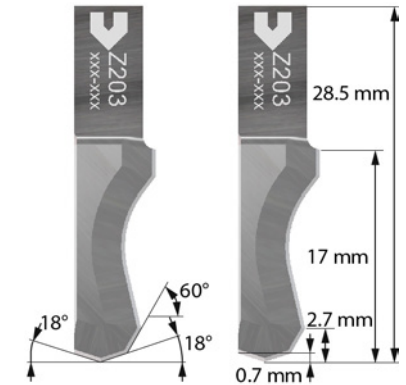
**Intended use**

EOT-250

**Z201****Item no.:** 5209201**Type**

Oscillating blade – flat

**Properties**

Oscillating blade with multifaceted bidirectional cutting edge for high-speed cutting of 16 mm paper-based honeycomb/corrugated display board.

**Recommended materials**

- Corrugated sandwich 16 mm

**Technical information**

Pre-cut: 6.4 mm

Post-cut: -

Max. cutting depth: 17.4 mm

Blade thickness: 1.5 mm

Blade material: Carbide

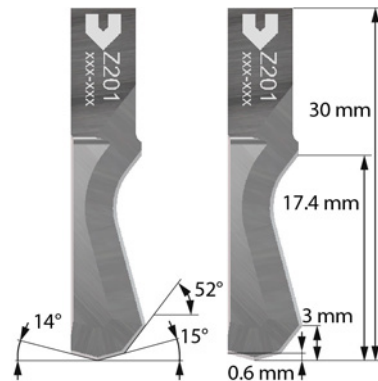
**Intended use**

EOT-250

**Z61****Item no.:** 5201343**Type**

Oscillating blade – flat

**Properties**

Very robust, heavy-duty oscillating blade.

**Recommended materials**

- Sandwich board
- Corrugated cardboard
- Corrugated plastic

**Technical information**

Pre-cut: 2.5 + 0.15 x Tm

Post-cut: -

Max. cutting depth: 20 mm

Blade thickness: 1.5 mm

Blade material: Carbide

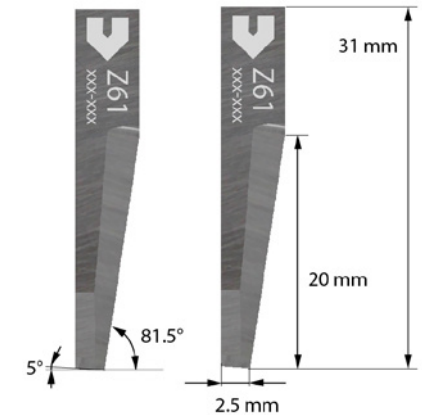
**Intended use**

EOT-250

POT,  
blade holder  
1.5 mm

**Z63**

Item no.: 5002637

**Type**

Oscillating blade – flat

**Properties**

Oscillating blade with small pre-cut. Similar to Z62, but longer and therefore a little less stable.

**Recommended materials**

- Foam
- Insulating mat

**Technical information**

Pre-cut: 0.8 + 0.12 x Tm

Post-cut: 1.20 mm

Max. cutting depth: 28 mm

Blade thickness: 0.63 mm

Blade material: Carbide

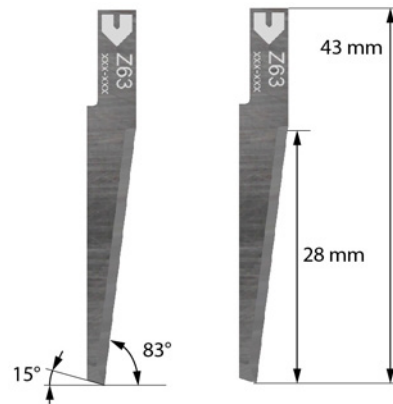
**Intended use**

EOT

EOT-250 +  
blade holder  
(5208744)POT,  
blade holder  
0.63 mmPOT, blade holder  
1.5 mm +  
blade reduction 1.5/  
0.63 mm (5003138)**Z68**

Item no.: 5204301

**Type**

Oscillating blade – flat

**Properties**

Blade for sandwich materials

**Recommended materials**

- Sandwich board
- Corrugated cardboard
- Corrugated plastic

**Technical information**

Pre-cut: 1.9 + 0.12 x Tm

Post-cut: -

Max. cutting depth: 29 mm

Blade thickness: 1.5 mm

Blade material: Carbide

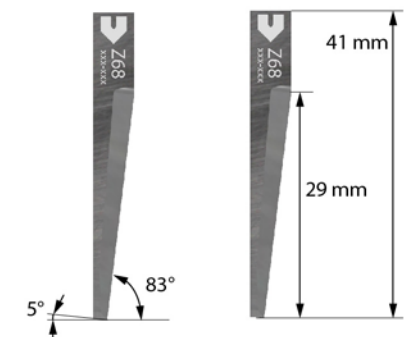
**Intended use**

EOT-250

POT,  
blade holder  
1.5 mm



**Z69**

Item no.: 5204302

**Type**

Oscillating blade – flat

**Properties**

Blade for sandwich materials

**Recommended materials**

- Sandwich board
- Corrugated cardboard
- Corrugated plastic

**Technical information**

Pre-cut: 1.7 + 0.11 x Tm

Post-cut: -

Max. cutting depth: 35 mm

Blade thickness: 1.5 mm

Blade material: Carbide

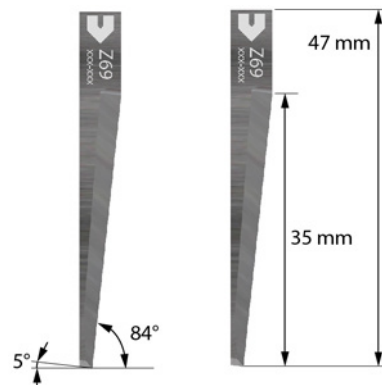
**Intended use**

EOT-250

POT,  
blade holder  
1.5 mm**Z607**

Item no.: 5210317

**Type**

Oscillating blade – flat

**Properties**Oscillating blade for soft foam up to 54 mm thickness and < 45 kg/m<sup>3</sup>**Recommended materials**

- Foam

**Technical information**

Pre-cut: 3.8 + 0.03 x Tm

Post-cut: -

Max. cutting depth: 56 mm

Blade thickness: 1.5 mm

Blade material: HSS

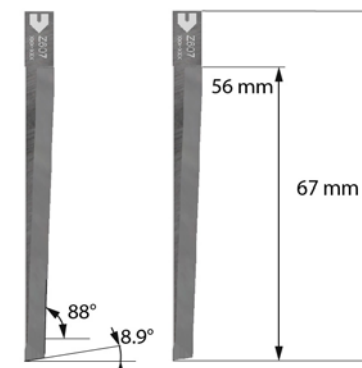
**Intended use**

EOT-250

POT,  
blade holder  
1.5 mm

**Z64**

Item no.: 5002739

**Type**

Oscillating blade – flat

**Properties**

Cost-effective blade for soft, thick materials.  
Short life expectancy!

**Recommended materials**

- Foam
- Insulating mat

**Technical information**Pre-cut:  $3.5 + 0.03 \times T_m$ 

Post-cut: -

Max. cutting depth: 57 mm

Blade thickness: 1.5 mm

Blade material: HSS

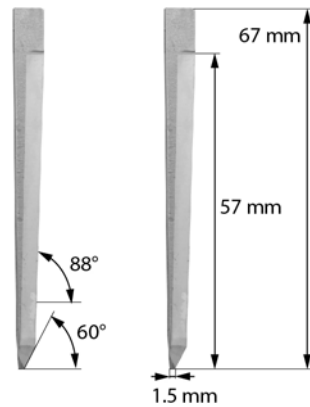
**Intended use**

POT,  
blade holder  
1.5 mm

**Z605**

Item no.: 5210319

**Type**

Oscillating blade – flat

**Properties**

Oscillating blade for soft foam up to 70 mm  
thickness and  $< 45 \text{ kg/m}^3$

**Recommended materials**

- Foam

**Technical information**Pre-cut:  $3.8 + 0.03 \times T_m$ 

Post-cut: -

Max. cutting depth: 72 mm

Blade thickness: 1.5 mm

Blade material: HSS

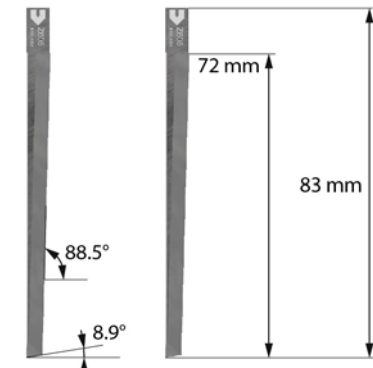
**Intended use**

EOT-250



POT,  
blade holder  
1.5 mm

**Z603****Item no.:** 5210320**Type**

Oscillating blade – flat

**Properties**Oscillating blade for soft foam up to 90 mm thickness and < 45 kg/m<sup>3</sup>**Recommended materials**

- Foam

**Technical information**

Pre-cut: 3.8 + 0.02 x Tm

Post-cut: -

Max. cutting depth: 92 mm

Blade thickness: 1.5 mm

Blade material: HSS

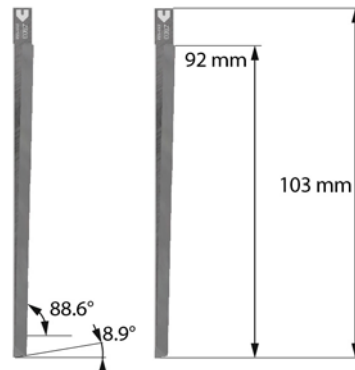
**Intended use**

EOT-250

POT,  
blade holder  
1.5 mm**Z601****Item no.:** 5209223**Type**

Oscillating blade – flat

**Properties**Oscillating blade for soft foam up to 110 mm thickness and < 45 kg/m<sup>3</sup>**Recommended materials**

- Foam

**Technical information**

Pre-cut: 3.8 + 0.02 x Tm

Post-cut: -

Max. cutting depth: 112 mm

Blade thickness: 1.5 mm

Blade material: HSS

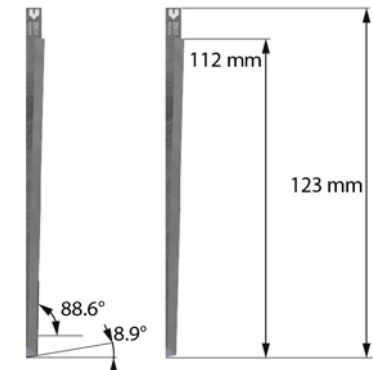
**Intended use**

EOT-250

POT,  
blade holder  
1.5 mm

**Z53****Item no.:** 4800059**Type**

Rotary blade

**Technical information**

Max. cutting depth: 2.0 mm

Blade thickness: 0.6 mm

Blade material: Carbide

**Properties**

Driven round-knife for cutting of single-layer textiles.

**Recommended materials**

- Aramid fibre
- Glass fibre
- Single-layer textiles
- Textiles

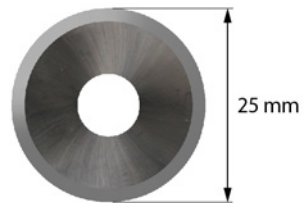
**Intended use**

DRT



PRT

**Z50****Item no.:** 3910335**Type**

Rotary blade

**Technical information**

Max. cutting depth: 3.5 mm

Blade thickness: 0.6 mm

Blade material: Carbide

**Properties**

Decagonal (10-sided) blade similar to Z51/ Z52, but with smaller overcut and greater cutting force.

**Recommended materials**

- Textiles
- Technical textiles
- Carbon fibre
- Glass fibre
- Aramid fibre

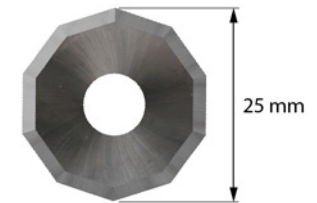
**Intended use**

DRT



PRT

**Z51****Item no.:** 3910336**Type**

Rotary blade

**Technical information**

Max. cutting depth: 5.0 mm

Blade thickness: 0.6 mm

Blade material: Carbide

**Properties**

Decagonal (10-sided) blade.

**Recommended materials**

- Textiles
- Technical textiles
- Carbon fibre
- Glass fibre
- Aramid fibre

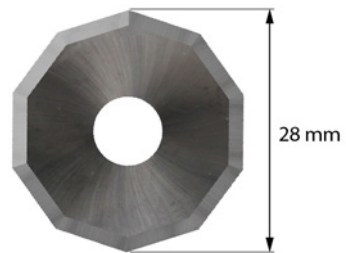
**Intended use**

DRT



PRT

**Z52****Item no.:** 3910337**Type**

Rotary blade

**Technical information**

Max. cutting depth: 7.0 mm

Blade thickness: 0.6 mm

Blade material: Carbide

**Properties**

Decagonal (10-sided) blade similar to Z50/Z51, but with larger overcut and lower cutting force.

**Recommended materials**

- Textiles
- Technical textiles
- Carbon fibre
- Glass fibre
- Aramid fibre

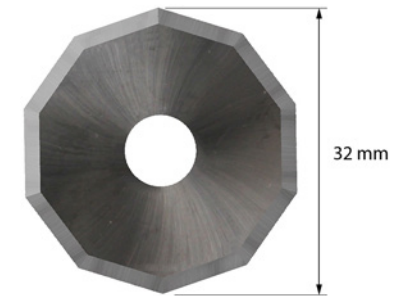
**Intended use**

DRT



PRT

**Z55**

Item no.: 5205751

**Type**

Wheel knife

**Properties**

Only use with a special PU cutting underlay.

**Recommended materials**

- Technical textiles (PES, PVC, etc.)
- Carbon fibre
- Glass fibre

**Technical information**

Max. cutting depth: 1 mm (single-layer)

Blade thickness: 0.3 mm

Blade material: HSS

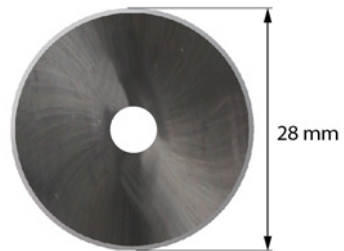
**Intended use**

WKT

**2.4 Wild knives**

Item no.	Knife
3910151	W1 40/35° single-edged
3910152	W2 30/35° single-edged
3910153	W5 30/30° double-edged
3910155	W7 30/35° single-edged long
3910156	W8 30/30° double-edged long
3910157	W9 30/45° single-edged long
3910158	WILD type 1 40/35° single-edged
3910159	WILD type 2 30/35° single-edged
3910160	WILD type 3 40/30° double-edged
3910161	WILD type 4 30/55° single-edged
3910322	Z40 HSS for EOT/POT tools

### 3 Routers

#### 3.1 RM-L / RM-A / RM-A QC / RM-A QC ARC / RM-S / R45-s

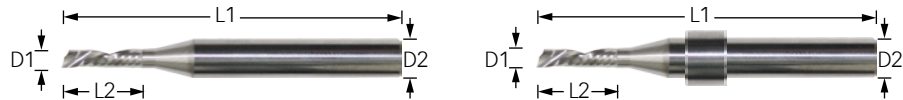

RXXX-A with stop ring (A-Version)

#### 3.1.1 Zünd multipurpose router<sup>1,2</sup>

Item no.	Type	D1 [mm]	D2 [mm]	Cutting	L1 [mm]	L2 [mm]	Max. rpm	Special	RM-L	RM-A	RM-A QC	RM-A QC ARC	RM-S	R45-s
5209418	R202	2	6	1	58	6	50000	-	•	•	•		•	•
5209419	R203	3	6	1	58	11	50000	-	•	•	•		•	•
5209420	R204	4	6	1	58	14	50000	-	•	•	•		•	•
5209421	R205	5	6	1	58	16	50000	-	•	•	•		•	•
5209422	R206	6	6	1	58	22	50000	-	•	•	•		•	•
5211434	R202-A	2	6	1	58	6	50000	A-Version				•		
5211435	R203-A	3	6	1	58	11	50000	A-Version				•		
5211436	R204-A	4	6	1	58	14	50000	A-Version				•		
5211437	R205-A	5	6	1	58	16	50000	A-Version				•		
5211438	R206-A	6	6	1	58	22	50000	A-Version				•		

<sup>1</sup> Acrylic, aluminum, Dibond, Forex, MDF, Pertinax, and plastics like PET, PP, PE, PVC-U, PS.

<sup>2</sup> Routers specially developed for Zünd Cutters. Suitable for hard as well as soft materials.

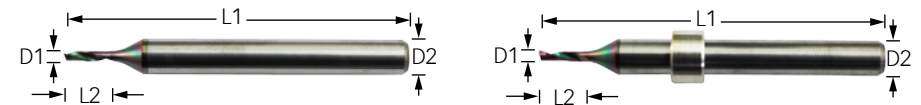

RXXX-A with stop ring (A-Version)

#### 3.1.2 Zünd multipurpose router bits coated<sup>1,2,3</sup>

Item no.	Type	D1 [mm]	D2 [mm]	Cutting	L1 [mm]	L2 [mm]	Max. rpm	Special	RM-L	RM-A	RM-A QC	RM-A QC ARC	RM-S	R45-s
5218133	R502	2	6	1	58	6	50000	-	•	•	•		•	•
5218135	R503	3	6	1	58	11	50000	-	•	•	•		•	•
5218137	R504	4	6	1	58	14	50000	-	•	•	•		•	•
5218139	R505	5	6	1	58	16	50000	-	•	•	•		•	•
5218141	R506	6	6	1	58	22	50000	-	•	•	•		•	•
5218134	R502-A	2	6	1	58	6	50000	A-Version				•		
5218136	R503-A	3	6	1	58	11	50000	A-Version				•		
5218138	R504-A	4	6	1	58	14	50000	A-Version				•		
5218140	R505-A	5	6	1	58	16	50000	A-Version				•		
5218142	R506-A	6	6	1	58	22	50000	A-Version				•		

<sup>1</sup> Acrylic, aluminum, Dibond, Forex, MDF, Pertinax, and plastics like PET, PP, PE, PVC-U, PS.

<sup>2</sup> Routers specially developed for Zünd Cutters. Suitable for hard as well as soft materials.

<sup>3</sup> Dry processing of aluminum (without Minimal Quantity Lubrication MQL).

3.1.3 Zünd ACM router<sup>1</sup>

Item no.	Type	D1 [mm]	D2 [mm]	Schneiden	L1 [mm]	L2 [mm]	Max. rpm	Special	RM-L	RM-A	RM-A QC	RM-A QC ARC	RM-S	R45-s
5212027	R207	2	6	1	58	6	50000	-	•	•	•		•	•
5212028	R208	3	6	1	58	8	50000	-	•	•	•		•	•
5212030	R209	4	6	1	58	8	50000	-	•	•	•		•	•
5212253	R207-A	2	6	1	58	6	50000	A-Version				•		
5212254	R208-A	3	6	1	58	8	50000	A-Version				•		
5212255	R209-A	4	6	1	58	8	50000	A-Version				•		

<sup>1</sup> Specific router for ACM (aluminum composite material), as Dibond, IGEP A Bond Premium, Basic IGPA, Alucobond, Reynobond, Dibond Digital, Dilite.

## 3.1.4 Acrylic, Aluminium

Item no.	Type	D1 [mm]	D2 [mm]	Cutting	L1 [mm]	L2 [mm]	Max. rpm	Special	RM-L	RM-A	RM-A QC	RM-A QC ARC	RM-S	R45-s
3910742	R102	2	6	1	50	6	50000	-		•	•		•	•
3910738	R108	3	6	1	50	6	50000	-		•	•		•	•
3910743	R103	3	6	1	50	11	50000	-		•	•		•	•
3910739	R109	4	6	1	50	6	46600	-		•	•		•	•
3910744	R104	4	6	1	50	14	46600	-		•	•		•	•
3910793	R170	4	6	1	50	22	46600	-	•	•	•		•	•
3910773	R173	5	6	1	50	16	37200	-		•	•		•	•
3910794	R171	5	6	1	58	22	37200	-	•	•	•		•	•
3910740	R101	6	6	1	50	12	31000	-		•	•		•	•
3910741	R100	6	6	1	58	22	31000	-		•	•		•	•
3910798	R172	6	6	1	64	32	31000	-	•	•	•		•	•
3910747	R123	3	6	1	50	11	50000	left-hand spiral bits	•	•	•		•	•
3910748	R124	4	6	1	50	12	46600	left-hand spiral bits	•	•	•		•	•
3910749	R125	5	6	1	50	12	37200	left-hand spiral bits	•	•	•		•	•
3910750	R126	6	6	1	60	22	31000	left-hand spiral bits	•	•	•		•	•
5211741	R123-A	3	6	1	50	11	50000	left-hand spiral bits, A-Version				•		
5211742	R124-A	4	6	1	50	12	46600	left-hand spiral bits, A-Version				•		
5211743	R126-A	6	6	1	60	22	31000	left-hand spiral bits, A-Version				•		



## 3.1.5 Forex, MDF, Wood, Dibond

Item no.	Type	D1 [mm]	D2 [mm]	Cutting	L1 [mm]	L2 [mm]	Max. rpm	Special	RM-L	RM-A	RM-A QC	RM-A QC ARC	RM-S	R45-s
3910762	R112	2	6	1	50	6	50000	-		•	•		•	•
3910761	R153	3	6	1	50	6	50000	-		•	•		•	•
3910763	R113	3	6	1	50	11	50000	-		•	•		•	•
3910709	R154	4	6	1	50	8	46600	-		•	•		•	•
3910764	R114	4	6	1	50	12	46600	-		•	•		•	•
3910795	R157	4	6	1	50	14	46600	-		•	•		•	•
3910796	R158	4	6	1	50	22	46600	-	•	•	•		•	•
3910758	R115	5	6	1	50	16	37200	-		•	•		•	•
3910797	R159	5	6	1	58	22	37200	-	•	•	•		•	•
3910759	R116	6	6	1	58	22	31000	-		•	•		•	•
3910771	R117	6	6	1	56	28	31000	-		•	•			•
3910710	R156	6	6	1	64	32	31000	-	•	•	•			•
3910767	R133	3	6	1	50	11	50000	left-hand spiral bits	•	•	•		•	•
3910768	R134	4	6	1	50	14	46600	left-hand spiral bits	•	•	•		•	•
3910769	R135	5	6	1	50	16	37200	left-hand spiral bits	•	•	•		•	•
3910770	R136	6	6	1	60	22	31000	left-hand spiral bits	•	•	•		•	•
5211744	R133-A	3	6	1	50	11	50000	left-hand spiral bits, A-Version				•		
5211745	R134-A	4	6	1	50	14	46600	left-hand spiral bits, A-Version				•		
5211746	R136-A	6	6	1	60	22	31000	left-hand spiral bits, A-Version				•		

3.1.6 Light foam < 52 kg/m<sup>3</sup>

Item no.	Type	D1 [mm]	D2 [mm]	Cutting	L1 [mm]	L2 [mm]	Max. rpm	Special	RM-L	RM-A	RM-A QC	RM-A QC ARC	RM-S	R45-s
3910726	R118	6	6	2	75	27	48000	2-flute		•				
3910727	R119	6	6	2	100	40	48000	2-flute		•				
3910728	R120	6	6	2	100	53	25000	2-flute		•				
3910729	R121	3	3	2	75	25	-	2-flute	•	•				
5211644	R219	6	6	2	85	40	48000	2-flute	•					
5211645	R220	6	6	2	90	53	25000	2-flute	•					
5211733	R118-A	6	6	2	75	27	48000	2-flute, A-Version			•	•		
5211734	R219-A	6	6	2	85	40	48000	2-flute, A-Version			•	•		
5211735	R220-A	6	6	2	90	53	25000	2-flute, A-Version			•	•		

3.1.7 Engraving bit

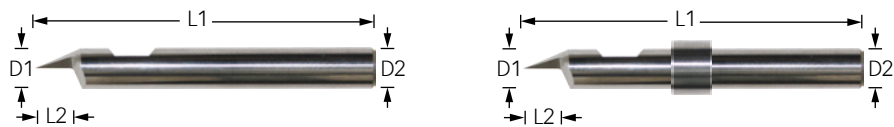

EX-A with stop ring (A-Version)

Item no.	Type	D1 [mm]	D2 [mm]	Cutting	L1 [mm]	L2 [mm]	Brackets	Max. rpm	Special	RM-L	RM-A	RM-A QC	RM-A QC ARC	RM-S	R45-s
3910506	E6	6	6	1	50	2.7	92°	50000	Acrylic, plastic	•	•	•		•	•
3910507	E7	6	6	1	50	4.7	60°	50000	Acrylic, plastic	•	•	•		•	•
3910508	E8	6	6	1	50	7.5	40°	50000	Acrylic, plastic	•	•	•		•	•
5211747	E6-A	6	6	1	50	2.7	92°	50000	A-Version				•		
5211748	E7-A	6	6	1	50	4.7	60°	50000	A-Version				•		
5211749	E8-A	6	6	1	50	7.5	40°	50000	A-Version				•		

3.1.8 Radius router

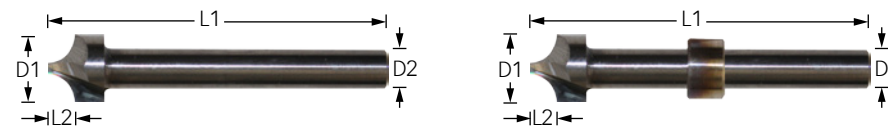

RXXX-A with stop ring (A-Version)

Item no.	Type	D1 [mm]	D2 [mm]	Cutting	L1 [mm]	L2 [mm]	Radius	Max. rpm	Special	RM-L	RM-A	RM-A QC	RM-A QC ARC	RM-S	R45-s
5213150	R210	6	6	2	50	2	2.0	50000	-	•	•	•		•	•
5213152	R211	10	6	2	50	4	4.0	50000	-	•	•	•		•	•
5213151	R210-A	6	6	2	50	2	2.0	50000	A-Version				•		
5213153	R211-A	10	6	2	50	4	4.0	50000	A-Version				•		

3.1.9 V-shape

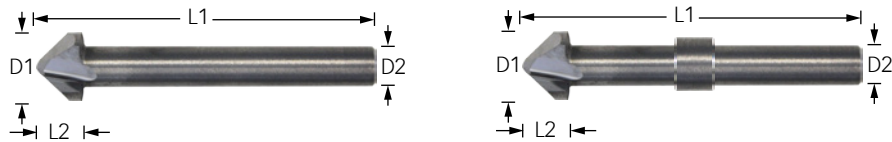

RXXX-A with stop ring (A-Version)

Item no.	Type	D1 [mm]	D2 [mm]	Cutting	L1 [mm]	L2 [mm]	Brackets	Max. rpm	Special	RM-L	RM-A	RM-A QC	RM-A QC ARC	RM-S	R45-s
3910760	R140	10	6	1	44.5	4.1	90°	20000	Acrylic, Dibond		•			•	•
3910799	R141	10	6	2	50	4	90°	40000	Acrylic, Dibond	•	•	•		•	•
5211751	R141-A	10	6	2	50	4	90°	40000	Acrylic, Dibond, A-Version				•		

3.1.10 Polisher

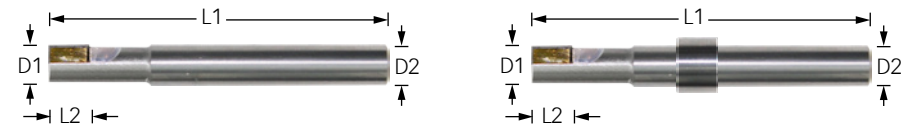

PXXX-A with stop ring (A-Version)

Item no.	Type	D1 [mm]	D2 [mm]	Cutting	L1 [mm]	L2 [mm]	Max. rpm	Special	RM-L	RM-A	RM-A QC	RM-A QC ARC	RM-S	R45-s
3910780	P106	6	6	1	50	6	41000	Acrylic, Diamond-polisher	•	•	•		•	•
5211750	P106-A	6	6	1	50	6	41000	Acrylic, A-Version				•		
5214210	P201	5.5	6	1	60	16	50000	Acrylic, Poly-cristalline Diamond-polisher	•	•	•		•	•
5214211	P201-A	5.5	6	1	60	16	50000	Acrylic, Poly-cristalline Diamond-polisher A-Version				•		

## 3.1.11 Custom router bits

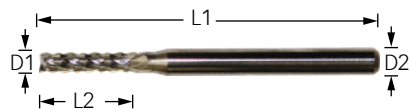

Item no.	Type	D1 [mm]	D2 [mm]	Cutting	L1 [mm]	L2 [mm]	Max. rpm	Special	RM-L	RM-A	RM-A QC	RM-A QC ARC	RM-S	R45-s
3910452	R62	2.4	1/8"	2	38	10	-	Pertinax						•

## 3.2 URT 300 W / PN 150/450 W



## 3.2.1 Acrylic, Aluminium

Item no.	Type	D1 [mm]	D2 [mm]	Cutting	L1 [mm]	L2 [mm]	Max. rpm	Special	URT	PN 150/450 W
3910730	R40	1	3	1	38	4	80000	-	•	•
3910734	R41	2	3	1	38	6	80000	-	•	•
3910735	R42	3	3	1	38	6	62000	-	•	•
3910737	R43	3	3	1	38	11	62000	-	•	•
3910700	R5	2	3	1	38	4	80000	left hand spiral bits	•	•
3910736	R44	3	3	1	38	6	62000	left hand spiral bits	•	•
3910705	R25	0.6	1/8"	2	38	3	-	2-flute		•
3910706	R26	0.8	1/8"	2	38	4.5	-	2-flute		•
3910707	R27	1	1/8"	2	38	4.5	-	2-flute		•
3910708	R28	1.2	1/8"	2	38	6	-	2-flute		•
3910701	R21	1.6	1/8"	2	38	8	-	2-flute		•
3910702	R22	2	1/8"	2	38	9	-	2-flute		•
3910703	R23	2.4	1/8"	2	38	9	-	2-flute		•
3910704	R24	3	1/8"	2	38	10	-	2-flute		•
3910718	R50	4	4	1	50	14	46000	-		•

## 3.2.2 Forex, MDF, Wood, Dibond

Item no.	Type	D1 [mm]	D2 [mm]	Cutting	L1 [mm]	L2 [mm]	Max. rpm	Special	URT	PN 150/450 W
3910752	R71	1	3	1	30	4	80000	-	•	•
3910753	R72	2	3	1	30	6	80000	-	•	•
3910755	R74	3	3	1	30	6	63600	-	•	•
3910756	R75	3	3	1	38	11	63600	-	•	•
3910754	R73	2	3	1	38	6	80000	left hand spiral bits	•	•
3910757	R76	3	3	1	38	11	63600	left hand spiral bits	•	•
3910715	R15	0.6	1/8"	1	38	2.5	-	-		•
3910716	R16	1	1/8"	1	38	4	-	-		•
3910717	R17	1.2	1/8"	1	38	5	-	-		•
3910711	R11	1.6	1/8"	1	38	5.5	-	-		•
3910712	R12	2	1/8"	1	38	9.5	-	-		•
3910713	R13	2.4	1/8"	1	38	9.5	-	-		•
3910714	R14	3	1/8"	1	38	9.5	-	-		•
3910720	R52	4	4	1	50	12	46600	-		•
3910719	R51	4	4	1	50	22	46600	-		•

## 3.2.3 Hard Brass

Item no.	Type	D1 [mm]	D2 [mm]	Cutting	L1 [mm]	L2 [mm]	Max. rpm	Special	URT	PN 150/450 W
3910424	R34	1	3	3	38	3	-	3-flute		•
3910421	R31	1.5	3	3	38	5	-	3-flute		•
3910422	R32	2	3	3	38	6	-	3-flute		•
3910425	R35	2.5	3	3	38	7	-	3-flute		•
3910423	R33	3	3	3	38	9	-	3-flute		•

3.2.4 Engraving bit



Item no.	Type	D1 [mm]	D2 [mm]	Cutting	L1 [mm]	L2 [mm]	Brackets	Max. rpm	Special	URT	PN 150/450 W
3910503	E3	3	3	1	38	3.9	36°	-	Engraving plates	•	•
3910509	E9	3	3	1	38	2.1	60°	-	Acrylic, Plastic	•	•
3910501	E1	3	3	1	38	1.3	90°	-	Acrylic, Plastic	•	•
3910502	E2	3	3	1	38	1.3	90°	-	Brass	•	•
3910505	E5	3	1/8"	1	38	2.1	60°	-	Acrylic, Plastic		•
3910504	E4	3	1/8"	1	38	1.3	90°	-	Acrylic, Plastic		•

3.2.5 Custom router bits



Item no.	Type	D1 [mm]	D2 [mm]	Cutting	L1 [mm]	L2 [mm]	Max. rpm	Special	URT	PN 150/450 W
3910452	R62	2.4	1/8"	2	38	10	-	Pertinax		•

## 4 Creasing wheels

### 4.1 CTT2 - Creasing inserts



Item no.	Type	Ø Creasing wheel [mm]	Creasing width [point]	Width [mm]	Depth [mm]	Notice
3910603	C201	24	4	1.5	1.0	Cardboard 250-400 g/m <sup>2</sup> without creasing matrix
3910604	C202	24	4	1.5	1.5	
3910602	C206	24	3	1.1	1.1	Cardboard 250-300 g/m <sup>2</sup> without creasing matrix
3910612	C208	24	3	1.1	1.1	
3910611	C207	24	2	0.7	1.0	
3910601	C205	24	2	0.7	0.7	
5002275	C204	15	3	1.1	1.5	
5002277	C203	15	2	0.7	1.0	
5003247	C209	24	-	Crusher	-	Radius 7mm, corrugated cardboard
5003246	C213	24	8	3.0	-	Corrugated plastic
5003245	C212	24	4	1.5	-	
3910607	C214	-	4	-	-	
3910606	C210	24	2	1.3	5.0	Parchment and soft materials
3910605	C211	14	1	0.25	1.5	PVC- and PP 0.5-1.2 mm
5002540	C001	-	3	1.0	-	CTT2 + knife holder type 1 PVC- and PP 0.5-1.2/0.5-1.0 mm
5002541	C002	-	1.5	0.5	-	CTT2 + knife holder type 1 PVC- and PP 0.5-1.2/0.5-1.0 mm

### 4.2 CTT1 - Crease wheel without support



Item no.	Type	Ø Creasing wheel [mm]	Catch R	Angle	Notice
5005632	C101	61	0.5	5°	corrugated cardboard < 4.5 mm
5005633	C102	61	0.5	10°	corrugated cardboard < 4.5 mm
5005634	C103	61	0.5	15°	corrugated cardboard < 4.5 mm

## Creasing wheels

CTT3 - Crease wheel without support

### 4.3 CTT3 - Crease wheel without support



Item no.	Type	Ø Creasing wheel [mm]	Catch R	Angle	Notice
5205823	C301	90	1.0	15°	Dual-layer corrugated cardboard > 4.5 mm
5205824	C302	90	0.5	15°	
5210477	C303	90	3	20°	
5210490	C304	90	3	10°	
5220226	C305	90	-	-	DISPA®

## Perforating knives

Vinyls

## 5 Perforating knives

### 5.1 Vinyls

Figure	Item no.	Item	Cut [mm]	Gap [mm]	Max. depth [mm]
	5212381	P111 25 TPI	0.7	0.3	1.1
	5212382	P112 17 TPI	1.1	0.5	1.1

### 5.2 Solid cardboard / Polypropylene

Figure	Item no.	Item	Cut [mm]	Gap [mm]	Max. depth [mm]
	5212383	P113 12 TPI	1.1	1.0	1.1





## Perforating knives

Corrugated cardboard

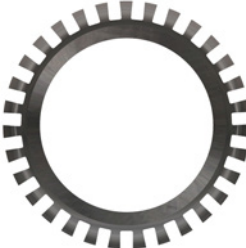

Figure	Item no.	Item	Cut [mm]	Gap [mm]	Max. depth [mm]
	5212384	P114 8 TPI	1.5	1.8	1.1

### 5.3 Corrugated cardboard

Figure	Item no.	Item	Cut [mm]	Gap [mm]	Max. depth [mm]
	5212385	P115 4 TPI	3.0	3.0	4.0
	5212386	P116 3 TPI	5.0	5.0	4.0

## Perforating knives

Knifeholder

Figure	Item no.	Item	Cut [mm]	Gap [mm]	Max. depth [mm]
	5212387	P117 2 TPI	7.0	5.0	4.0
	5212388	P118 1.5 TPI	10.0	10.0	4.0

### 5.4 Knifeholder

Figure	Item no.	Item
	5211782	Knifeholder perforating knife

## Punching bits

HSS punching bits

### 6 Punching bits

#### 6.1 HSS punching bits

Figure	Item no.	Punch Ø [mm]	Tool holder Ø [mm]
	3999211	0.5	7
	3999213	0.8	7
	3999201	1	7
	3999200	1.2	7
	3999202	1.5	7
	3999203	2	7
	3999204	2.5	7
	3999205	3	7
	3999206	3.5	7
	3999207	4	7
	3999208	4.5	7
	3999209	5	7
	3999210	5.5	7

## Punching bits

Carbide punching bits

#### 6.2 Carbide punching bits

Figure	Item no.	Punch Ø [mm]	Tool holder Ø [mm]
	3999101	1	4.5
	3999102	1.5	4.5
	3999103	2	4.5
	3999104	2.5	4.5
	3999105	3	7
	3999106	3.5	7
	3999107	4	7
	3999108	4.5	7
	3999109	5	7

## Punching bits

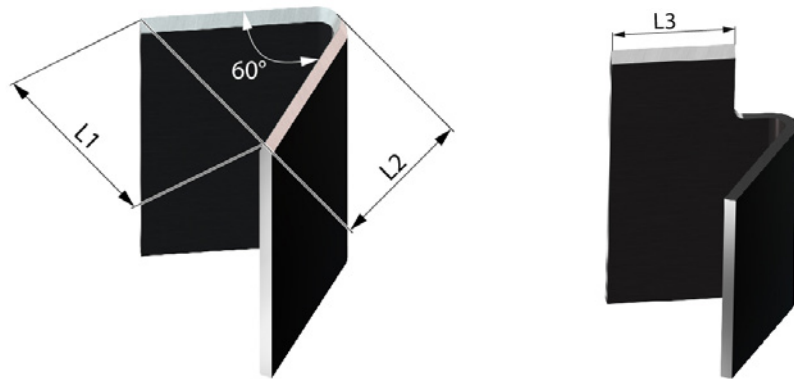

Notching bit

### 6.3 Notching bit



Item no.	Type	$\alpha$	L1 [mm]	L2 [mm]	L3 [mm]
5218062	N101	60°	7.9	6	-
5218063	N102	60°	4.4	3	-
5218064	N103	-	-	-	5

### 6.4 Punching pin

Figure	Item no.	Tool holder Ø [mm]
	3999111	4.5
	3999112	7

## Tools

Punching pin



### 7 Tools

Figure	Item no.	Item
	5206113	UCT, CTT2 [insert sleeve 40 for Tz-Module complete with glide shoe; does not include blade holder]
	5206112	UCT, CTT2 [insert sleeve 40 for Tz-Module; does not include glide shoe; creasing tool holder does not include blade holder]
	3102202	KCT [insert sleeve 40 for Tz-module for vinyl cutting (spring can be used to adjust downward pressure)]
	3120133	UDT [Pen insert sleeve 40 for Tz-module]
	3120098	Insert sleeve 28 for 2T-module; does not include glide shoe (for Tz-2T-P tool heads)
	5005638	CTT1 [creasing wheel holder]
	5212151	PTT1 (Perforating tool with knifeholder)
	5219976	PCT [Press Cutting Tool + Glideshoe B1, without blade holder]

## Cutting accessories

Notching bit

### 8 Cutting accessories

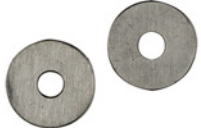
Figure	Item no.	Item
	5003138	blade reduction 1.5/0.6 mm for POT-40/1.5; enables the use of blades with 0.63 mm shank thickness (Z20, Z41, etc.)
	5003139	blade reduction 1.5/1.0 mm for POT-40/1.5; enables the use of blades with 1 mm shank thickness
	5206051	2 guide rails, WKT Ø 5/18 mm
	5212508	Knife adjustment tool EOT-250 / POT, 1.5 mm

## Cutting accessories

Blade holder, flat-stock drag blade

### 8.1 Blade holder, flat-stock drag blade

Figure	Item no.	Item
	3960322	Type 1 (silver) for centric blades, 1.5 mm thick (Z10, Z11, Z44, Z83)
	3960323	Type 2 (blue) for centric blades, 0.63 mm thick (Zünd type 2, Zünd type 3)
	3960324	Type 3 (yellow) for eccentric blades, 0.63 mm thick (Z16, Z17, Zünd type 6)
	3960320	Type 5 for eccentric blades, 1.5 mm thick (Z46)
	5002251	Type 1 (silver) [goes with insert sleeve 28 for 2T-module (Z10, Z11, etc.)]
	5002252	Type 2 (blue) [goes with insert sleeve 28 for 2T-module (Zünd type 2, Zünd type 3, etc.)]
	5002253	Type 3 (yellow) [goes with insert sleeve 28 for 2T-module (Z16, Z17, etc.)]

**Cutting accessories**



Blade holder, V-cut blade

**8.2 Blade holder, V-cut blade**

Figure	Item no.	Item
	5005928	Blade holder 16 mm compl.; goes with trapeze blade (VCT G3)
	5005929	Blade holder 10 mm compl.; goes with carbide blade (VCT G3)
	5005930	Blade holder 16 mm compl.; goes with carbide blade (VCT G3)

**Cutting accessories**



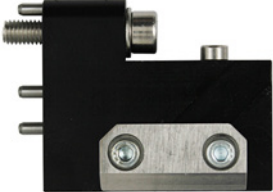

Blade holder, V-cut blade

Figure	Item no.	Item
	5206262	Blade holder 16 mm compl.; goes with trapeze blade (VCT S3/G3)
	5206264	Blade holder 16 mm compl.; goes with carbide blade (VCT S3/G3)
	5206263	Blade holder 10 mm compl.; goes with carbide blade (VCT S3/G3)

## Cutting accessories

Blade holder, PPT blade



### 8.3 Blade holder, PPT blade

Figure	Item no.	Item
	3960331	Knife holder for PPT; for Z30/Z31
	3960328	Knife holder for PPT up to 5 mm; for Z33
	3960329	Knife holder for PPT up to 2.5 mm; for Z33
	3960330	Knife holder for PPT; for Z35

## Cutting accessories

EOT

### 8.4 EOT

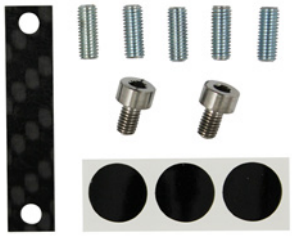
Figure	Item no.	Item
	5005885	Blade guide (EOT)
	5201162	Bearing (EOT)
	5901424	5 set screws, EOT blade holder
	5200665	Service set 2, connecting rod

8.5 EOT-250

Figure	Item no.	Item
	5208744	Knife holder 0.6 mm
	5208751	Knife holder 1.5 mm
	5208745	Service set
	5210884	Friction bearing
	5204325	Bearing

8.6 Glide shoes

Figure	Item no.	Item
	3120026	Gliding shoe, 4 mm spring deflection (EOT-40, EOT-3)
	5811445	Gliding shoe, 8 mm spring deflection (UCT)
	3120029	Gliding shoe, rigid (UCT, SCT)
	5205984	Gliding shoe, 12 mm spring deflection, metal (POT+Z82)

## Cutting accessories

Glide shoes

Figure	Item no.	Item
	5811541	Gliding shoe, 12 mm spring deflection (POT, EOT)
	3120033	Gliding shoe, 12 mm (POT, EOT3), without pressure spring
	3120114	Glide element, 12.5 mm (9.25 x 2.5 mm slot), for gliding shoe 3120033 (self-assembly)
	3120143	Gliding shoe, height-adjustable (POT, EOT)

## Cutting accessories

Glide shoes



Figure	Item no.	Item
	5220612	Gliding shoe, rigid (PCT)
	3120028	Gliding shoe, 8 mm deflection path with large slot for Tz module
	5002146	Glider, rigid [2T-sleeve 28]
	3120021	Glide shoe for blade holder (KCM-S, KCT, C2)
	3120030	Spring insert – low-strength
	3120031	Spring insert – medium-strength
	3120032	Spring insert – high-strength



## Cutting accessories

KCM-S, KCT, C2-, C2-P-modular tool heads

### 8.7 KCM-S, KCT, C2-, C2-P-modular tool heads





Figure	Item no.	Description
	3910130	ZÜND type blade changer (for blade types Z1-Z5)
	3120013	Cartridge holder for KCM-S, C2
	3120011	blade holder for KCM-S, C2, C2-P tool head (for vinyl blades)
	3120012	blade holder for KCM-S, C2, C2-P tool heads with glide shoe, suitable for „Diamond Grade“ vinyl
	3120018	Ejector spring for sleeve, C2/KCM-S
	3620106	Spring insert, blue (spring tension 0.24 - 0.96 N) for KCT/CP/sleeve 40 (guided)
	3620107	Spring insert, yellow (spring tension to 7 N) for KCT/CP/sleeve 40 (guided)
	3620108	Andruckfeder, gelb (Federkraft bis 7 N) [KCT / CP / Hülse 40 gef.]
	3620117	Spring insert, special (spring tension to 20 N) for KCT/CP/sleeve 40 (guided)

## Routing accessories

Collets HSK-E 25, 3.6 kW milling spindle

### 9 Routing accessories

#### 9.1 Collets HSK-E 25, 3.6 kW milling spindle

Figure	Item no.	Description
	5812807	ER16, Ø 4 mm, for shank diameter 3.0 - 4.0 mm
	5812613	ER16, Ø 6 mm, for shank diameter 5.0 - 6.0 mm
	5813108	ER16, Ø 7 mm, for shank diameter 6.0 - 7.0 mm
	5812808	ER16, Ø 8 mm, for shank diameter 7.0 - 8.0 mm
	5812799	Collet holder HSK-E 25

#### 9.2 Collets, 1 kW milling spindle

Figure	Item no.	Description
	3910500	Ø 1/8 " (3.175 mm)
	3910497	Ø 1/4 " (6.35mm)
	3910498	Ø 3.0 mm
	3910499	Ø 4.0 mm
	3910496	Ø 6.0 mm

## Routing accessories

Collets, 1 kW milling spindle, QC





### 9.3 Collets, 1 kW milling spindle, QC

Figure	Item no.	Description
	5812106	Ø 6.0 mm

### 9.4 Collets, 300 W milling spindle

Figure	Item no.	Description
	3910491	Ø 3.0 mm

### 9.5 Collets, 150/450 W milling spindle

Figure	Item no.	Description
	3910492	Ø 1/8 " (3.175 mm)
	3910494	Ø 2.0 mm
	1527491	Ø 2.5 mm
	3910491	Ø 3.0 mm
	3910493	Ø 4.0 mm

## Routing accessories







Consumables

### 9.6 Consumables

Figure	Item no.	Description
	5212231	Brush, router type RM-L
	3621213	Brush, router types RZP, R45, R module, URT
	5005271	Brush, milling type R45s, RM-A
	5202125	MQL lubricant, Accu-Lube LB4500, 1-litre container



## Routing accessories

Collets, 1 kW milling spindle, QC

Figure	Item no.	Description
	3621210	Glide shoe for suction bell (RM-A) [R-/R45-module]
	5211032	Clamping pin for pneumatic collet, Ø 6.0 mm
	5812569	Cylindric wiper, Ø 6.0 mm
	5812831	Cylindric wiper, Ø 8.0 mm
	5812821	Conical cleaner
	5813295	Cone cleaner for motor spindle

## Routing accessories

Collets, 1 kW milling spindle, QC





Figure	Item no.	Description
	5210057	Router bit holder silver, Ø 9.0 mm, (ARC RM-A QC)
	5210058	Router bit holder black, Ø 10.5 mm, (ARC RM-A QC)
	5210059	Router bit holder red, Ø 10.0 mm, (ARC RM-A QC)
	5212478	Router bit holder, (ARC HSK RM-L)

## Plotting accessories

Insert sleeves, cartridges/cartridge holders

### 10 Plotting accessories

#### 10.1 Insert sleeves, cartridges/cartridge holders

Figure	Item no.	Description
	3910223	Insert sleeve for long-life cartridge (Super Giant)
	3910222	Insert sleeve for silver cartridge
	3205430	Insert sleeve for edding 400/404 (permanent marker)
	5202649	Insert sleeve for edding 1880/140s
	3910200	Insert sleeve for ballpoint cartridge

## Plotting accessories

Cartridges

#### 10.2 Cartridges

Figure	Item no.	Item
	3910201	Ballpoint cartridge black
	3910202	Ballpoint cartridge blue
	3910203	Ballpoint cartridge green
	3910204	Ballpoint cartridge red
	3910224	Long-life cartridge black (Super Giant)
	3910205	Ballpoint cartridge silver

## 11 Cutting and routing underlays



### Cutting underlay PLP (anthracite)

Standard board for cutter models without material transport. Due to the max. raw material size of 1500 x 1000 mm, larger cutting areas must be covered with multiple elements.

Thickness: 2.5 mm



### Cutting underlay S (anthracite)

Underlay from the same material as models with material transport (conveyor belt). The polyester non-woven material (PET) reinforced with textile fabric is available in one piece for all cutting area sizes.

Thickness: 2.8 mm



### Cutting underlay ST (brown)

Thin cutting underlay, primarily used for cutting through in vinyl cutting solutions. Facilitates an optimized cutting edge and clean, defined baseline when using recorders. Max. available width 1800 mm.

Thickness: 1.0 mm

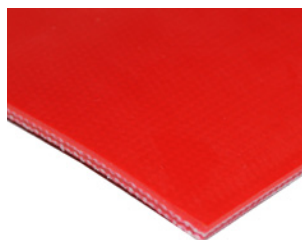

### PU cutting underlay coated (red)

Cutting underlay with a thick PU layer for the cutting process using a wheel knife tool (WKT). Vacuum adhesion is not possible because it is airtight.

PU layer: 2.0 mm.

Total thickness: 5.1 mm



### Sealgrip routing underlay

Routing underlay with special adhesion conditions for material hold-down during the routing process.

Material dimension 1000 x 1600 mm – also available as 1 x 30 m roll material.

Thickness: 2.0 mm



### Sealgrip W routing underlay

Routing underlay with special adhesion conditions for material hold-down during the routing process.

Material width 1530 mm

Thickness: 2.0 mm

## Cutting and routing underlays

Bulk materials

### 11.1 Bulk materials

Item no.	Item
2500200	Cutting underlay PLP (anthracite), 2.5 mm, 1500 x 1000 mm
2500201	Cutting underlay ST (brown), 1.0 mm, 1800 x 20000 mm

### 11.2 Sealgrip routing underlay

Item no.	Item
5200362	Sealgrip routing underlay, 1000 x 1600 mm
3912208	Sealgrip routing underlay, 1 m x 30 m roll

### 11.3 Sealgrip W routing underlay

Item no.	Item
5217164	Sealgrip W routing underlay, 1530 mm x 2500 mm
5217165	Sealgrip W routing underlay, 1530 mm x 3200 mm
5217163	Sealgrip W routing underlay, 1.53 m x 60 m roll

## Cutting and routing underlays

G3-Series

### 11.4 G3-Series

Cutter	Cutting underlay PLP (anthracite)		Cutting underlay S (anthracite)		PU cutting underlay coated red	
	Item no.	Quantity	Item no.	Quantity	Item no.	Quantity
M-1600	3930010	2	3912241	1	3940010	1
M-2500	3930002	3	3930202	1	3940002	1
L-2500	3930001	4	3930201	1	3940001	1
L-3200	3930004	6	3930204	1	3940004	1
XL-1600	3930009	4	3930205	1	-	-
XL-3200	3930003	8	3930203	1	-	-
2XL-1600	3930008	4	3930206	1	-	-
2XL-3200	3930007	8	3912170	1	-	-
3XL-1600	3930005	6	3930243	1	-	-
3XL-2500	3930011	8	3930207	1	-	-
3XL-3200	3930006	12	3930208	1	-	-

## Cutting and routing underlays

S3-Series

### 11.5 S3-Series

Cutter	Cutting underlay PLP (anthracite)		Cutting underlay S (anthracite)		Cutting underlay ST (brown)	
	Item no.	Quantity	Item no.	Quantity	Item no.	Quantity
M-800	3934001	2	3912229	1	3915000	1
M-1200	3934002	2	3912239	1	a. A.	
M-1600	3930010	2	3912241	1	a. A.	
L-1200	3934004	4	3912240	1	a. A.	
L-1600	3934005	4	3912237	1	a. A.	
XL-1200	3934006	4	3912242	1	a. A.	

### 11.6 L3-Series

Cutter	Cutting underlay PLP (anthracite)		Cutting underlay S (anthracite)		Cutting underlay S (green)	
	Item no.	Quantity	Item no.	Quantity	Item no.	Quantity
L3 C-40	-	-	3936001	1	3936003	1
L3 C-56	-	-	3936002	1	3936004	1

## Cutting and routing underlays

PN-Series

### 11.7 PN-Series

Cutter	Cutting underlay PLP (anthracite)		Cutting underlay S (anthracite)		Cutting underlay ST (brown)	
	Item no.	Quantity	Item no.	Quantity	Item no.	Quantity
S-800	3912140	1	3912147	1	3912143	1
M-800	3912120	1	3912150	1	3912125	1
M-1200	3912121	2	3912151	1	3912126	1
M-1600	3912122	2	3912152	1	3912127	1
L-800	3912123	2	3912153	1	3912128	1
L-1200	3912124	2	3912154	1	3912129	1
LR-1600	3912135	4	3912155	1	3912141	1
LH-1600	3912135	4	3912155	1	3912141	1
L-2500	3912136	4	3912156	1	3912142	2
L-3000	3912164	6	3912166	1	3912165	2
XL-800	3912137	2	3912157	1	3912132	1
XL-1200	3912138	4	3912158	1	3912133	1
XL-1600	3912134	4	-	-	3912145	2
XL-2500	3912139	6	3912159	1	3912146	2
XL-3000	3912167	8	3912169	1	3912168	2
2XL-3000	3912184	8	-	-	-	-
3XL-3000	-	-	3912186	1	-	-

## Cutting and routing underlays

LC-Series

### 11.8 LC-Series

Cutter	Cutting underlay PLP (anthracite)		Cutting underlay S (anthracite)		Cutting underlay S (anthracite) 4.0 mm	
	Item no.	Quantity	Item no.	Quantity	Item no.	Quantity
LC-2400	3912171	3	3912181	1	3912160	1
LC-1400	3912112	1	-	-	3912148	1
LC-1800	3912111	2	-	-	3912149	1
LC-2600	3912113	2	-	-	3912161	1
LC-5200	3912114	3	-	-	3912162	1
LC-16/52	-	-	-	-	3912172	1
LC-27/32	-	-	-	-	3912163	2

### 11.9 P-Series

Cutter	Cutting underlay PLP (anthracite)		Cutting underlay ST (brown)	
	Item no.	Quantity	Item no.	Quantity
P-700	3912101	1	3912105	1
P-1200	3912102	2	3912106	1
P-1600	3912109	2	3912110	1
P-2000	3912107	4	3912108	1

## Conveyor belts

Accessories

## 12 Conveyor belts

### 12.1 Accessories

Item no.	Item
5211233	Conveyor assembly glue, 50 ml (includes mixing jets and spatula)
3913000	Special conveyor assembly glue
3110997	Special fabric tape, 50 mm wide, 5 m long
5802298	Applicator gun

### 12.2 G3 series

#### 12.2.1 M-1600

Item no.	Item
3923055	Conveyor belt, M-1600
3923056	Conveyor belt, M-1600 + M-CE800
3923057	Conveyor belt, M-1600 + M-CE800 + M-CE800
3923058	Conveyor belt, M-1600 + M-CE1600 + M-CE800
3923059	Conveyor belt, M-1600 + M-CE1600
3923060	Conveyor belt, M-1600+M-CE1600+M-CE1600



**Conveyor belts**

G3 series

**12.2.2 M-2500**

Item no.	Item
3923002	Conveyor belt, M-2500
3923003	Conveyor belt, M-2500 + M-CE1250
3923004	Conveyor belt, M-2500 + M-CE2500
3923013	Conveyor belt, M-2500 + M-CE1250 + M-CE1250
3923014	Conveyor belt, M-2500 + M-CE2500 + M-CE2500
3923015	Conveyor belt, M-2500 + M-CE1250 + M-CE2500
3923061	Conveyor belt, M-2500 + 2XM-CE2500 front
3923062	Conveyor belt, M-2500+M-CE0800

**12.2.3 L-2500**

Item no.	Item
3923001	Conveyor belt, L-2500
3923005	Conveyor belt, L-2500 + L-CE1250
3923006	Conveyor belt, L-2500 + L-CE2500
3923016	Conveyor belt, L-2500 + L-CE1250 + L-CE1250
3923017	Conveyor belt, L-2500 + L-CE2500 + L-CE2500
3923018	Conveyor belt, L-2500 + L-CE1250 + L-CE2500
3923081	Conveyor belt, L-2500 + L-CE3200
3923108	Conveyor belt, L-2500 + L-CE3200 + L-CE1250
3923105	Conveyor belt, L-2500 + L-CE3200 + L-CE3200

**Conveyor belts**

G3 series

**12.2.4 L-3200**

Item no.	Item
3923007	Conveyor belt, L-3200
3923008	Conveyor belt, L-3200 + L-CE1600
3923009	Conveyor belt, L-3200 + L-CE3200
3924083	Conveyor belt, L-3200 + L-CE3500
3923019	Conveyor belt, L-3200 + L-CE1600 + L-CE1600
3923020	Conveyor belt, L-3200 + L-CE3200 + L-CE3200
3924085	Conveyor belt, L-3200 + L-CE3500 + L-CE3500
3923021	Conveyor belt, L-3200 + L-CE1600 + L-CE3200
3924084	Conveyor belt, L-3200+L-CE3500+L-CE1600
3923080	Conveyor belt, L-3200+L-CE1250

**12.2.5 XL-1600**

Item no.	Item
3923025	Conveyor belt, XL-1600
3923026	Conveyor belt, XL-1600 + XL-CE800
3923030	Conveyor belt, XL-1600 + XL-CE1600
3923027	Conveyor belt, XL-1600 + XL-CE800 + XL-CE800
3923029	Conveyor belt, XL-1600 + XL-CE1600 + XL-CE1600
3923028	Conveyor belt, XL-1600 + XL-CE800 + XL-CE1600

## Conveyor belts

G3 series

### 12.2.6 XL-3200

Item no.	Item
3923010	Conveyor belt, XL-3200
3923011	Conveyor belt, XL-3200 + XL-CE1600
3923012	Conveyor belt, XL-3200 + XL-CE3200
3924086	Conveyor belt, XL-3200 + XL-CE3500
3923022	Conveyor belt, XL-3200 + XL-CE1600 + XL-CE1600
3923023	Conveyor belt, XL-3200 + XL-CE3200 + XL-CE3200
3924088	Conveyor belt, XL-3200 + XL-CE3500 + XL-CE3500
3923024	Conveyor belt, XL-3200 + XL-CE1600 + XL-CE3200
3924087	Conveyor belt, XL-3200 + XL-CE1600 + XL-CE3500

### 12.2.7 2XL-1600

Item no.	Item
3923031	Conveyor belt, 2XL-1600
3923032	Conveyor belt, 2XL-1600 + 2XL-CE800
3923036	Conveyor belt, 2XL-1600 + 2XL-CE1600
3923033	Conveyor belt, 2XL-1600 + 2XL-CE800 + 2XL-CE800
3923035	Conveyor belt, 2XL-1600 + 2XL-CE1600 + 2XL-CE1600
3923034	Conveyor belt, 2XL-1600 + 2XL-CE800 + 2XL-CE1600

## Conveyor belts

G3 series

### 12.2.8 2XL-3200

Item no.	Item
3923037	Conveyor belt, 2XL-3200
3923038	Conveyor belt, 2XL-3200 + 2XL-CE1600
3923042	Conveyor belt, 2XL-3200 + 2XL-CE3200
3924089	Conveyor belt, 2XL-3200 + 2XL-CE3500
3923039	Conveyor belt, 2XL-3200 + 2XL-CE1600 + 2XL-CE1600
3923041	Conveyor belt, 2XL-3200 + 2XL-CE3200 + 2XL-CE3200
3924091	Conveyor belt, 2XL-3200 + 2XL-CE3500 + 2XL-CE3500
3923040	Conveyor belt, 2XL-3200 + 2XL-CE1600 + 2XL-CE3200
3924090	Conveyor belt, 2XL-3200 + 2XL-CE3500 + 2XL-CE1600

### 12.2.9 3XL-1600

Item no.	Item
3923043	Conveyor belt, 3XL-1600
3923044	Conveyor belt, 3XL-1600 + 3XL-CE800
3923048	Conveyor belt, 3XL-1600 + 3XL-CE1600
3923045	Conveyor belt, 3XL-1600 + 3XL-CE800 + 3XL-CE800
3923047	Conveyor belt, 3XL-1600 + 3XL-CE1600 + 3XL-CE1600
3923046	Conveyor belt, 3XL-1600 + 3XL-CE800 + 3XL-CE1600

**12.2.10 3XL-2500**

Item no.	Item
3923063	Conveyor belt, 3XL-2500
3923064	Conveyor belt, 3XL-2500 + 3XL-CE1250
3923065	Conveyor belt, 3XL-2500 + 3XL-CE2500
3923066	Conveyor belt, 3XL-2500 + 3XL-CE1250 + 3XL-CE1250
3923067	Conveyor belt, 3XL-2500 + 3XL-CE2500 + 3XL-CE1250
3923068	Conveyor belt, 3XL-2500 + 3XL-CE2500 + 3XL-CE2500

**12.2.11 3XL-3200**

Item no.	Item
3923049	Conveyor belt, 3XL-3200
3923050	Conveyor belt, 3XL-3200 + 3XL-CE1600
3923054	Conveyor belt, 3XL-3200 + 3XL-CE3200
3924092	Conveyor belt, 3XL-3200 + 3XL-CE3500
3923051	Conveyor belt, 3XL-3200 + 3XL-CE1600 + 3XL-CE1600
3923053	Conveyor belt, 3XL-3200 + 3XL-CE3200 + 3XL-CE3200
3924094	Conveyor belt, 3XL-3200 + 3XL-CE3500 + 3XL-CE3500
3923052	Conveyor belt, 3XL-3200 + 3XL-CE1600 + 3XL-CE3200
3924093	Conveyor belt, 3XL-3200 + 3XL-CE3500 + 3XL-CE1600

**12.3 S3 series**

**12.3.1 M-800**

Item no.	Item
3933001	Conveyor belt, M-800
3933002	Conveyor belt, M-800+M-CE800
3933003	Conveyor belt, M-800+M-CE800+M-CE800

**12.3.2 M-1200**

Item no.	Item
3933004	Conveyor belt, M-1200
3933005	Conveyor belt, M-1200+M-CE1200
3933006	Conveyor belt, M-1200+M-CE1200+M-CE1200

**12.3.3 M-1600**

Item no.	Item
3933007	Conveyor belt, M-1600
3933008	Conveyor belt, M-1600+M-CE1600
3933009	Conveyor belt, M-1600+M-CE1600+M-CE1600

**12.3.4 L-1200**

Item no.	Item
3933010	Conveyor belt, L-1200
3933011	Conveyor belt, L-1200+L-CE1200
3933012	Conveyor belt, L-1200+L-CE1200+L-CE1200

## Conveyor belts

S3 series

### 12.3.5 L-1600

Item no.	Item
3933013	Conveyor belt, L-1600
3933014	Conveyor belt, L-1600+L-CE1600
3933015	Conveyor belt, L-1600+L-CE1600+L-CE1600

### 12.3.6 XL-1200

Item no.	Item
3933016	Conveyor belt, XL-1200
3933017	Conveyor belt, XL-1200+XL-CE1200
3933018	Conveyor belt, XL-1200+XL-CE1200+XL-CE1200

## Conveyor belts

D3 series

### 12.4 D3 series

#### 12.4.1 L-3200

Item no.	Item
3937001	Conveyor belt, D3 L-3200
3937002	Conveyor belt, D3 L-3200 + L-CE1600
3937003	Conveyor belt, D3 L-3200 + L-CE3500
3937004	Conveyor belt, D3 L-3200 + L-CE-1600 + L-CE1600
3937005	Conveyor belt, D3 L-3200 + L-CE-3500 + L-CE3500
3937006	Conveyor belt, D3 L-3200 + L-CE-1600 + L-CE3500

#### 12.4.2 XL-3200

Item no.	Item
3937007	Conveyor belt, D3 XL-3200
3937008	Conveyor belt, D3 XL-3200 + XL-CE1600
3937009	Conveyor belt, D3 XL-3200 + XL-CE3500
3937010	Conveyor belt, D3 XL-3200 + XL-CE-1600 + XL-CE1600
3937011	Conveyor belt, D3 XL-3200 + XL-CE-3500 + XL-CE3500
3937012	Conveyor belt, D3 XL-3200 + XL-CE-1600 + XL-CE3500

#### 12.4.3 2XL-3200

Item no.	Item
3937013	Conveyor belt, D3 2XL-3200
3937014	Conveyor belt, D3 2XL-3200 + 2XL-CE1600
3937015	Conveyor belt, D3 2XL-3200 + 2XL-CE3500

## Conveyor belts

D3 series

Item no.	Item
3937016	Conveyor belt, D3 2XL-3200 + 2XL-CE-1600 + 2XL-CE1600
3937017	Conveyor belt, D3 2XL-3200 + 2XL-CE-3500 + 2XL-CE3500
3937018	Conveyor belt, D3 2XL-3200 + 2XL-CE-1600 + 2XL-CE3500

### 12.4.4 3XL-3200

Item no.	Item
3937019	Conveyor belt, D3 3XL-3200
3937020	Conveyor belt, D3 3XL-3200 + 3XL-CE1600
3937021	Conveyor belt, D3 3XL-3200 + 3XL-CE3500
3937022	Conveyor belt, D3 3XL-3200 + 3XL-CE-1600 + 3XL-CE1600
3937023	Conveyor belt, D3 3XL-3200 + 3XL-CE-3500 + 3XL-CE3500
3937024	Conveyor belt, D3 3XL-3200 + 3XL-CE-1600 + 3XL-CE3500

## Conveyor belts

PN series

### 12.5 PN series

#### 12.5.1 S-800

Item no.	Item
3913011	Conveyor without CVE
3913100	Conveyor with CVE-08 – one side

#### 12.5.2 M-800

Item no.	Item
3913021	Conveyor without CVE
3913073	Conveyor with CVE-08 – one side
3913054	Conveyor with CVE-12 – one side

#### 12.5.3 M-1200

Item no.	Item
3913023	Conveyor without CVE
3913132	Conveyor with CVE-08 – one side
3913055	Conveyor with CVE-12 – one side

#### 12.5.4 M-1600

Item no.	Item
3913025	Conveyor without CVE
3913082	Conveyor with CVE-12 – one side
3913076	Conveyor with CVE-16 – one side
3913027	Conveyor with CVE-16 – both sides

## Conveyor belts

PN series

### 12.5.5 L-800

Item no.	Item
3913031	Conveyor without CVE
3913050	Conveyor with CVE-12 – one side

### 12.5.6 L-1200

Item no.	Item	Hint
3913039	Conveyor without CVE	< Serial number: L12009
3913033	Conveyor without CVE	> Serial number: L12008
3913051	Conveyor with CVE-12 – one side	
3913034	Conveyor with CVE-12 – both sides	

### 12.5.7 LR-1600

Item no.	Item
3913048	Conveyor without CVE
3913074	Conveyor with CVE-12 – one side
3913056	Conveyor with CVE-16 – one side
3913071	Conveyor with CVE-16 – both sides

### 12.5.8 LH-1600

Item no.	Item
3913035	Conveyor without CVE
3913057	Conveyor with CVE-16 – one side

## Conveyor belts

PN series

### 12.5.9 L-2500

Item no.	Item	Hint
3913037	Conveyor without CVE	< Serial no. L25007
3913038	Conveyor without CVE	> Serial no. L25006
3913066	Conveyor with CVE-12 – one side	
3913058	Conveyor with CVE-25 – one side	
3913067	Conveyor with CVE-25 – both sides	

### 12.5.10 L-3000

Item no.	Item
3913061	Conveyor without CVE
3913087	Conveyor with CVE-12 – one side
3913063	Conveyor with CVE-25 – one side
3913089	Conveyor with CVE-30 – one side
3913086	Conveyor with CVE-30 – both sides

### 12.5.11 XL-800

Item no.	Item
3913041	Conveyor without CVE
3913052	Conveyor with CVE-12 – one side

**Conveyor belts**

PN series

**12.5.12 XL-1200**

Item no.	Item
3913043	Conveyor without CVE
3913053	Conveyor with CVE-12 – one side
3913088	Conveyor XL-1200 + CVE-12 + CVE-12

**12.5.13 XL-1600**

Item no.	Item
3913046	Conveyor without CVE
3913077	Conveyor with CVE-16 – one side

**12.5.14 XL-2500**

Item no.	Item
3913047	Conveyor without CVE
3913064	Conveyor with CVE-25 – one side
3913044	Conveyor belt with CVE-30
3913156	Conveyor with CVE-25 – both sides

**Conveyor belts**

PN series

**12.5.15 XL-3000**

Item no.	Item
3913049	Conveyor without CVE
3913153	Conveyor with CVE-12
3913151	Conveyor with CVE-16
3913065	Conveyor with CVE-25 – one side
3913103	Conveyor with CVE-30 – one side

**12.5.16 2XL-3000**

Item no.	Item
3913096	Conveyor without CVE
3913138	Conveyor with CVE-12 – one side
3913101	Conveyor with CVE-30 – one side
3913095	Conveyor with CVE-30 – both sides

**12.5.17 3XL-3000**

Item no.	Item
3913105	Conveyor without CVE
3913114	Conveyor with CVE-30 – one side

**Zünd Systemtechnik AG**

Industriestrasse 8  
CH-9450 Altstätten  
T +41 71 554 81 00  
info@zund.com  
www.zund.com

**ZÜND**   
swiss cutting systems