

Tandem Vacuum System

With tandem vacuum, the active working area of the cutter can be divided into front and back processing areas. Minimizing machine idle time, this tandem-production workflow is highly efficient and leads to significant increases in productivity.

The active working area equipped with a tandem vacuum system permits controlling the vacuum on each side of the machine independently. Each processing area has the necessary controls for turning the vacuum on/off and resuming production after reloading. For positioning the material, the vacuum can be de- and re-activated in the respective processing area. As soon as the material is properly positioned, simply push the resume button and cutting continues.

This type of «pendulum» production allows for concurrent un-/reloading and cutting/processing. While the material is loaded/unloaded on one side, the machine continues cutting/processing the material on the other. This saves time and maximizes productivity by keeping machine idle time to a minimum.

Another benefit of having two independent vacuum areas is the ability to turn off the vacuum in one or the other and thereby limit

it to the exact size of the material. This eliminates unwanted airflow by restricting the vacuum to where it is needed.

Any jobs for which the tandem vacuum workflow is not suitable or desirable can be processed using the entire working area.

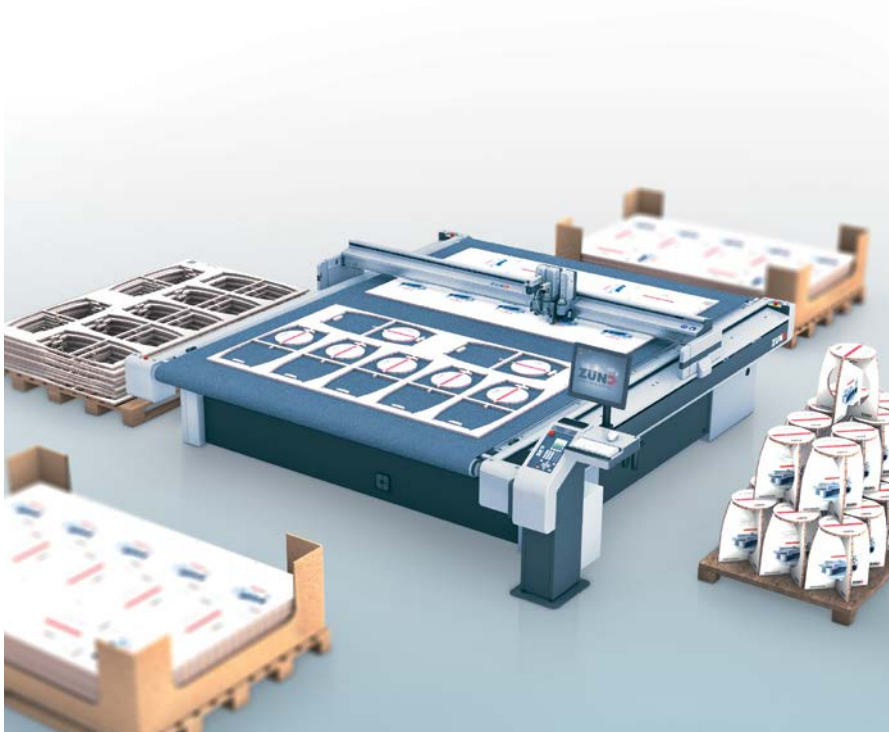

ZS107-2015-m&k

Details G3

The width of the vacuum area over the entire working area can be set from either side.

Available for G3 cutter sizes M-2500, L-2500, L-3200, XL-3200, 2XL-3200, 3XL-2500, 3XL-3200.

Available in combination with any Zünd G3 vac. turbine

Details S3

The vacuum width can be set across the entire working area from right to left.

Available for cutter sizes M-1600, L-1600.

Requires use of two vacuum pumps.

Benefits at a glance

In addition to setting the vacuum width, two vacuum plates (one behind the other) can be switched independently of each other.

In the tandem processing mode, loading/unloading and processing take place in parallel.

User-friendly placement of the processing release and vacuum on/off keys. For G3 optionally also on both sides of the cutter.

Two LEDs per working area signal to the operator that loading and unloading can be done safely.

Efficient utilization of the working surface.

Depending on the job it is possible to switch between the job processes with divided working surface and standard operation.

Working Areas **G3** (L x W)

Series	2500	3200
M	1250 x 1330 mm / 49" x 52"	-
L	1250 x 1800 mm / 49" x 70"	1600 x 1800 mm / 63" x 70"
XL	-	1600 x 2270 mm / 63" x 89"
2XL	-	1600 x 2740 mm / 63" x 107"
3XL	1250 x 3210 mm / 49" x 126"	1600 x 3210 mm / 63" x 126"

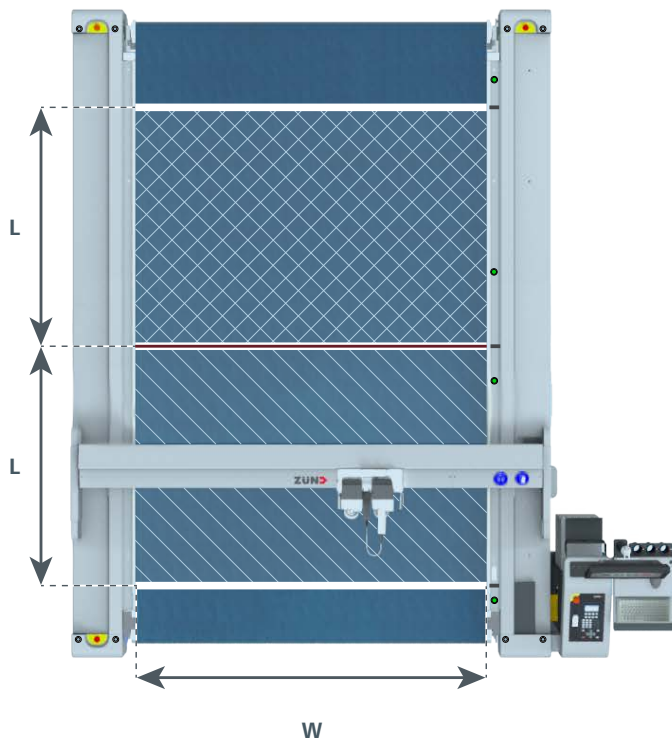

Working Areas **S3** (L x W)

Series	1600
M	815 x 1300 mm / 32" x 52"
L	815 x 1800 mm / 32" x 70"

Note:

The rear vacuum area on S3 machines is shortened by 35 mm/1.38".

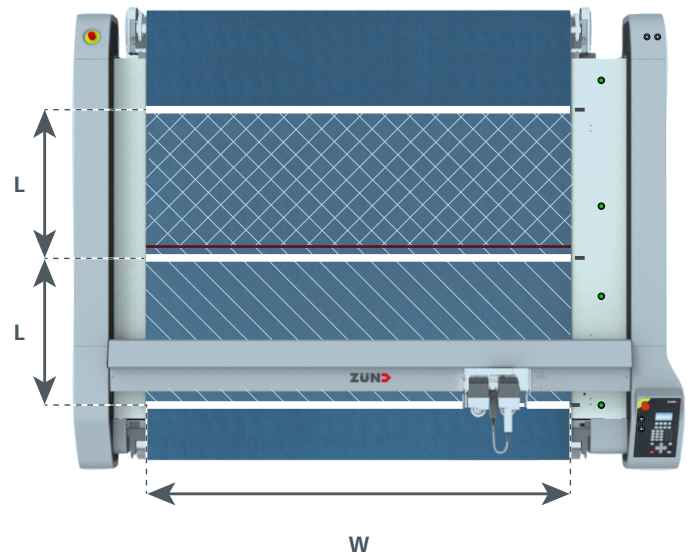

Legend:

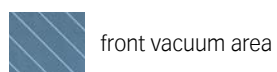

front vacuum area



rear vacuum area



borderline between the vacuum areas