

# Collection Tray

The collection tray is a convenient option for catching cut parts and waste as they come off the conveyor belt. It adds a level of automation while keeping cut materials from falling to the floor and maintaining a clean work area.

The collection tray is an optional device designed to collect materials (cut parts and/or waste, depending on the application) coming off the conveyor belt.

The tray can be opened, and even removed, at any time during the cutting process. This makes it easy to inspect and remove cut parts without having to interrupt production.

The collection tray can be easily detached from the cutter for emptying. When not in use, it can be pushed back out of the way.

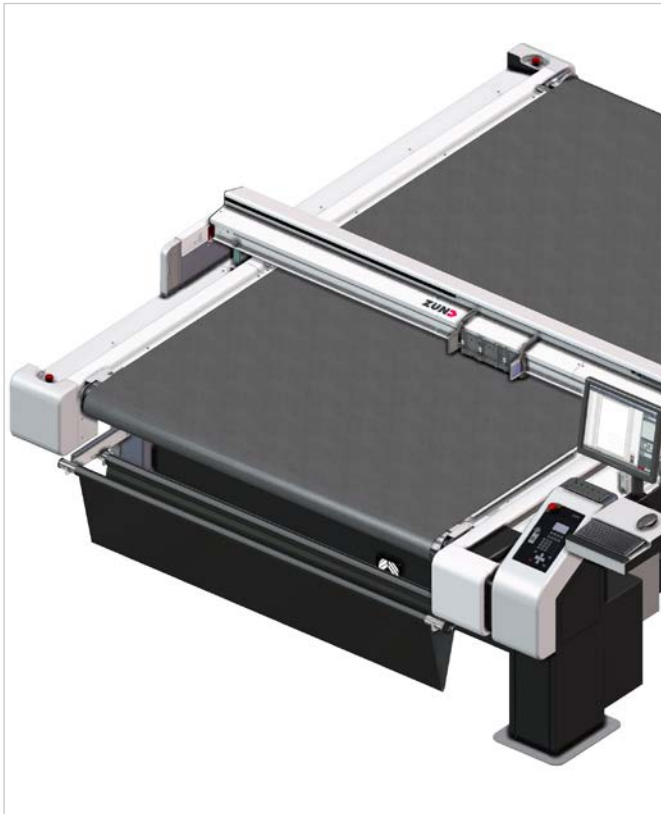

## Details

Compatible with **G3**, **S3**.



## Advantages at a glance

Attachable to cutter or cutter extension

A convenient option for catching cut parts and waste