

# Over Cutter Camera – OCC

**The Over Cutter Camera captures all register marks visible in the working area of the cutter with a single shot – automatically and in a matter of seconds.**

The OCC is an intelligent, fully automated optical registration system. It is designed to digitally capture registration marks with a camera mounted above the center of the cutting system, either attached to a support frame or suspended from the ceiling.

As expansion to Zünd's proven ICC technology, the OCC represents significant advances in registration speed and therefore in overall productivity.

Regardless of the thickness of the printed substrates, high-end optics reliably capture all register marks in a single image and process them in a matter of seconds.

Until now users were applying register marks to their graphics fully aware that reading each

mark would take precious time and, especially on larger systems and with extra-wide materials, the beam-mounted ICC camera would have to travel long distances to capture all the marks. With new, one-shot OCC technology, it no longer matters how many register marks are added or where they are located in the cutting area, which leads to significant gains in the overall productivity of the cutting system.

OCC data processing functions are completely integrated in the ZCC software: in seconds, powerful algorithms analyze the camera data and compensate for distortions. Following each material advance, the OCC automatically captures another image and pro-

duction resumes automatically as soon as the registration data has been processed.

Boards and sheets can be placed anywhere in the working area since the OCC determines location and orientation with a single image. Exact placement of the material becomes irrelevant.

For jobs that require the highest possible accuracy, there is always the option to register cut to print with the ICC camera. The ICC captures each register mark individually at full resolution. The two systems complement each other perfectly and provide the user with the best possible solution for every production scenario.

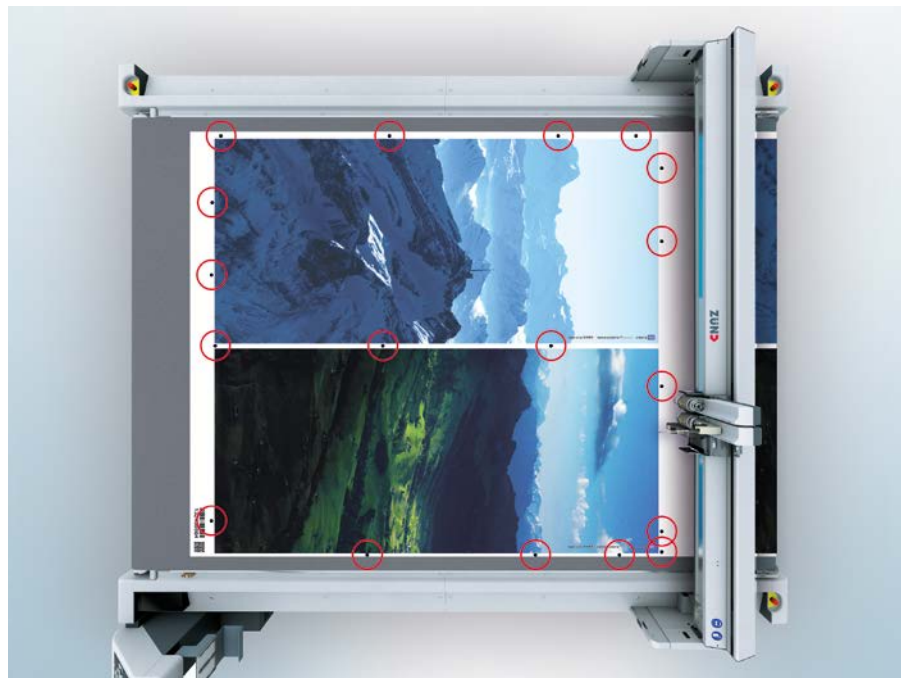

## Details

The OCC field of view covers the entire working area of all cutter sizes.

Recommended register-mark size: 6–12mm / .47 in

Requires both ICC and ZCC camera options.

Lighting in the working area may affect image quality and the ability of ZCC to process the captured image data.

### Over Cutter Camera, 50 MP / 14 mm

- Compatible with **G3** from ZCC Version 3.0.2
- Compatible with **D3** from ZCC Version 3.2.0

### Over Cutter Camera, 50 MP / 24 mm

- Compatible with **S3** from ZCC Version 3.1.2

## Benefits at a glance

One-shot technology enables capturing all register marks at once, resulting in significant time savings and productivity increases.

Reduces manual intervention in the production workflow.

Completely supported in Zünd Cut Center - ZCC with algorithms that intelligently process image data in a matter of seconds.

Fully compatible with ICC camera, seamless transitions from one system to the other.

Compatible with all Zünd modules/tools, incl. those requiring vacuum extraction (see following pages for details).

# Mounting guide, configurations without hose support

For configurations without modules or tools that require hose support, the following options are available for mounting the OCC:

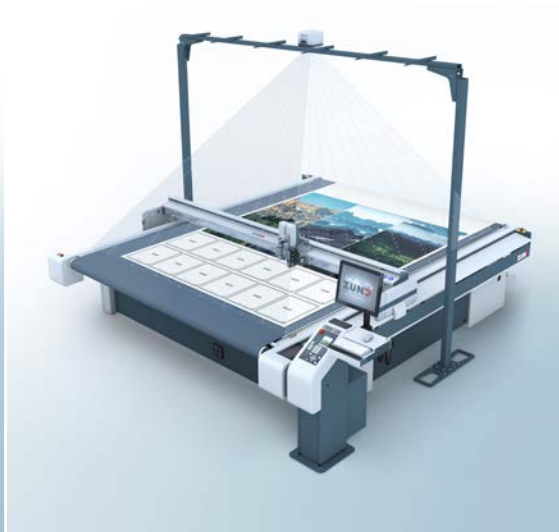
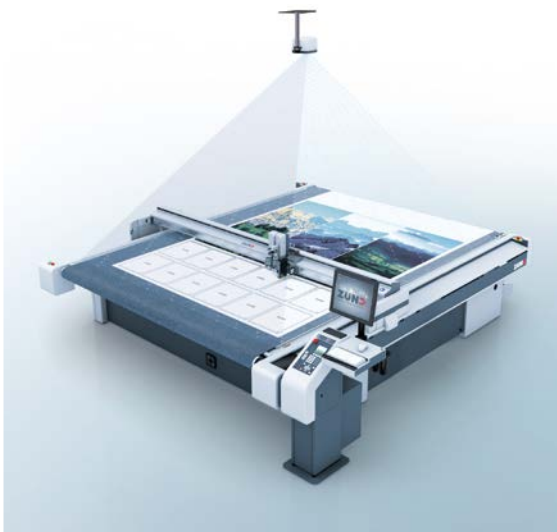

Series	Size	Ceiling mount	Mounting on support frame
G3	M-1600	✓	–
	M-2500	✓	✓
	L-2500	✓	✓
	L-3200	✓	✓
	XL-1600	✓	–
	XL-3200	✓	✓
	2XL-1600	✓	–
	2XL-3200	✓	✓
	3XL-1600	✓	–
	3XL-2500	✓	✓
	3XL-3200	✓	✓
D3	L-3200	✓	✓
	XL-3200	✓	✓
	2XL-3200	✓	✓
	3XL-3200	✓	✓
S3	M-800	✓	✓
	M-1200	✓	✓
	M-1600	✓	✓
	L-1200	✓	✓
	L-1600	✓	✓
	XL-1200	✓	✓

**Legend:**

- ✓ Mounting possible
- Mounting impossible

**Ceiling height requirements G3/D3:**

Support frame: min. 3.2m / 10.5ft  
 Ceiling mount: 3.2–4.4m / 10.5–14.5ft

**Ceiling height requirements S3:**

Support frame: min. 2.9m / 9.5ft  
 Ceiling mount M-800, M-1200, L-1200: 2.43–3.73m / 8–12.2ft  
 Ceiling mount M-1600, L-1600, XL-1200: 2.77–4.07m / 9.1–13.4ft

**Ground anchoring recommended:**

Anchor the support frame into the ground for better performance: 8 holes, 10x65 mm

# Mounting guide, configurations with hose support

Generally speaking, the OCC is compatible with all modules and tools; however, depending on the specific cutting system configuration, certain limitations may apply:

Series	Size	RM-A / RM-L / RM-S / URT / PRT			LM	Ink-Jet
		On gantry	On support frame	Mounted to ceiling	On support frame	On gantry
<b>G3</b>	M-1600	B <sup>*)</sup>	–	–	–	B <sup>*)</sup>
	M-2500	B <sup>*)</sup>	A	–	A	B <sup>*)</sup>
	L-2500	B <sup>*)</sup>	A	–	A	B <sup>*)</sup>
	L-3200	B	A	–	A	B
	XL-1600	B	–	–	–	B
	XL-3200	B	A	–	A	–
	2XL-1600	–	–	–	–	–
	2XL-3200	–	A	–	A	–
	3XL-1600	–	–	–	–	–
	3XL-2500	–	A	–	A	–
3XL-3200	–	A	–	A	–	
<b>D3</b>	L-3200	–	A	–		
	XL-3200	–	A	–		
	2XL-3200	–	A	–		
	3XL-3200	–	A	–		
<b>S3</b>	M-800	–	A	–		
	M-1200	–	A	–		
	M-1600	–	A	–		
	L-1200	–	A	–		
	L-1600	–	A	–		
	XL-1200	–	A	–		

**Legend:**

- A Mounting on support frame possible
- B Ceiling mount possible
- Mounting impossible

**\*) Note:**

Hoses and cables must be tied back when modules/tools are stored in module holder.

**Ceiling height requirements G3/D3:**

Support frame: min. 3.2m / 10.5ft  
 Ceiling mount: 3.2–4.4m / 10.5–14.5ft

Exceptions for ceiling mount in combination with gantry:

M-line: 3.2–4.0m / 10.5–13.1ft  
 L-line: 3.2–4.2m / 10.5–13.8ft

**Ceiling height requirements S3:**

Support frame: min. 2.9m / 9.5ft  
 Ceiling mount M-800, M-1200, L-1200: 2.43–3.73m / 8–12.2ft  
 Ceiling mount M-1600, L-1600, XL-1200: 2.77–4.07m / 9.1–13.4ft